



Confocal Principle

Jerry Fan

Application Engineer

ZEISS Research Microscopy Solutions Taiwan

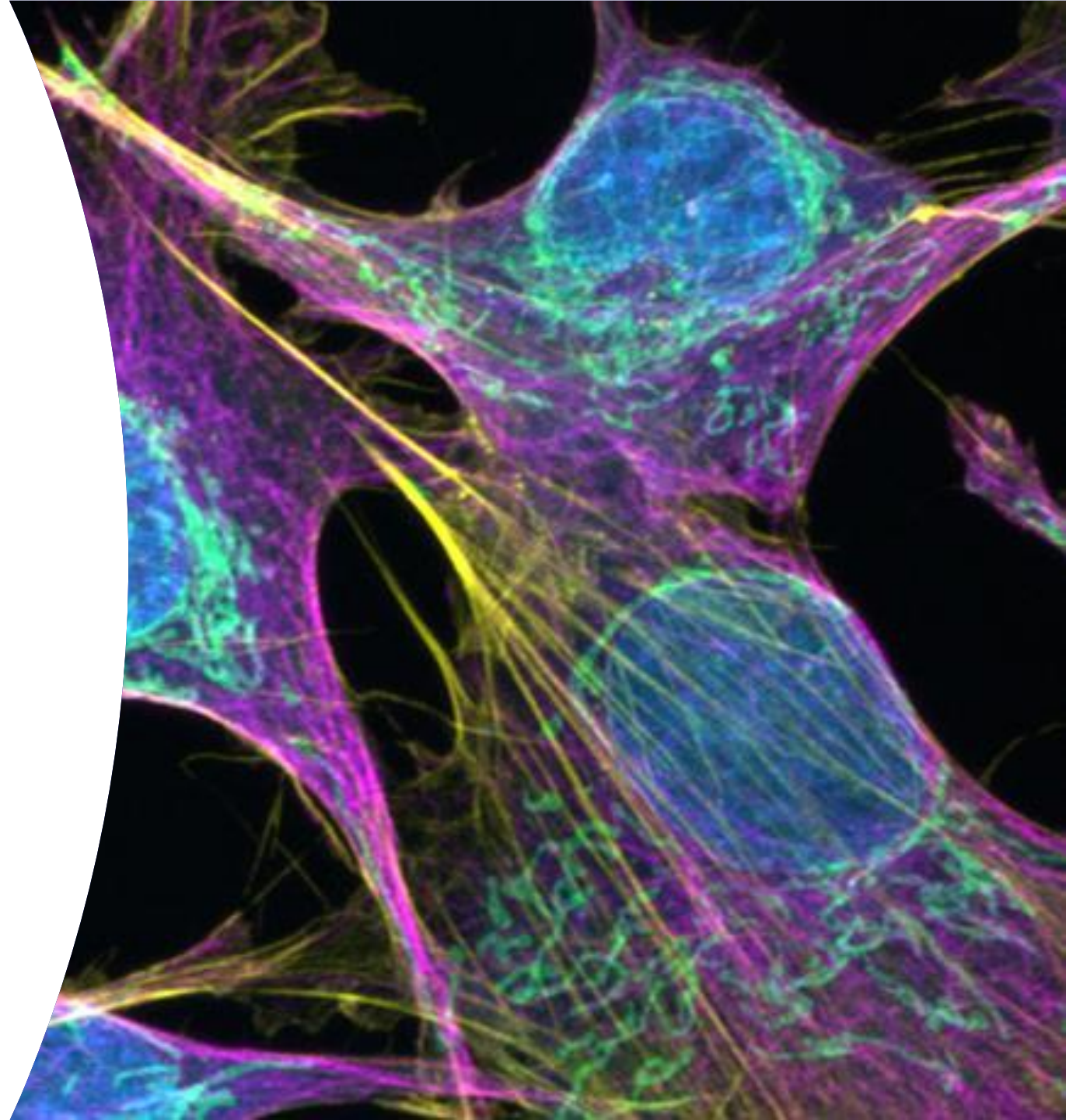

Bioinformatics Research



Internet connection

10 years old laptop

Molecular Biology Research



- DNA/RNA sequences
- Mass Spectrometer
- qPCR
- Fluorescence Microscopes
- Confocal Microscopes
- Electron Microscopes
- High-Speed Centrifuges
- Gel Electrophoresis
- Microplate Readers
- Incubators
- Pipettes & Pipettors
- Vortex Mixers
- Hot Plates
- Petri Dishes
- Well Plates
- Laboratory Freezers
- Autoclaves
- HPLC Systems
- Live-Cell Imaging
- Single-Cell Analysis

Keep the Context of Your Experiments

X-ray Light Microscopy Electron Microscopy Ion

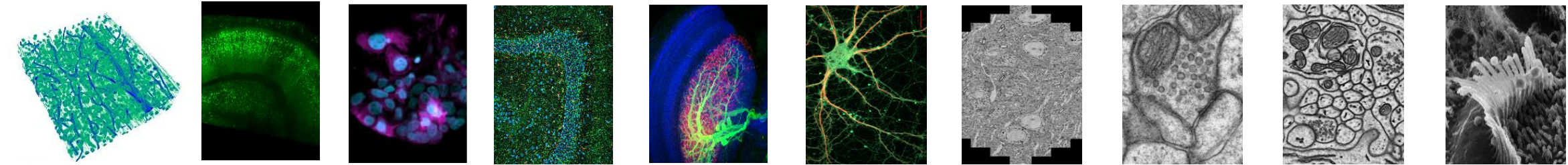
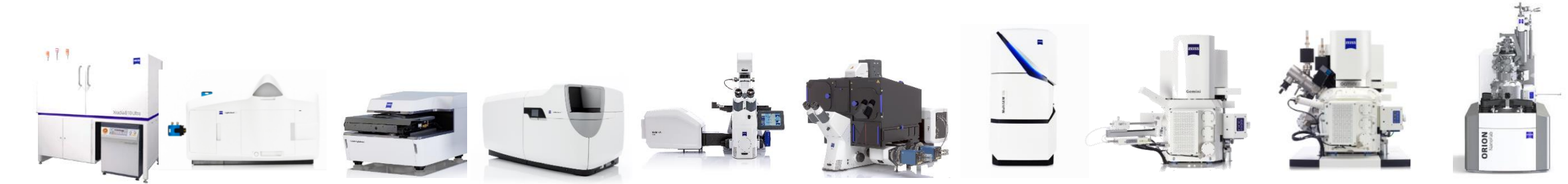

X-ray Lightsheet Lattice Lightsheet Widefield LSM Airyscan Super-resolution MultiSEM Field Emission Scanning Electron Focused Ion Beam Helium Ion

700 nm 500 nm 290 nm 250 nm 120 nm 20 nm 5 nm < 2 nm < 1 nm < 0.5 nm



The Applications of Light Microscopy

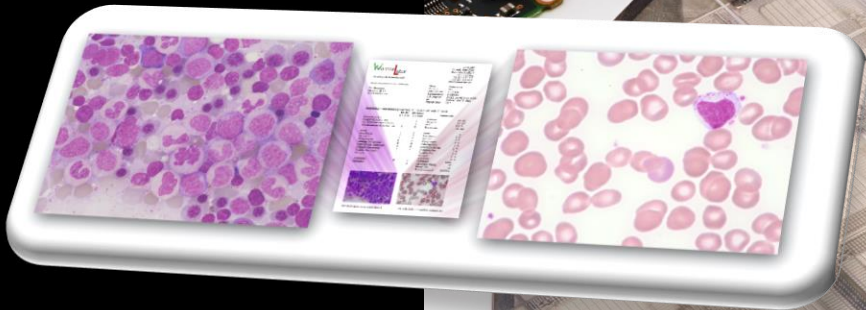
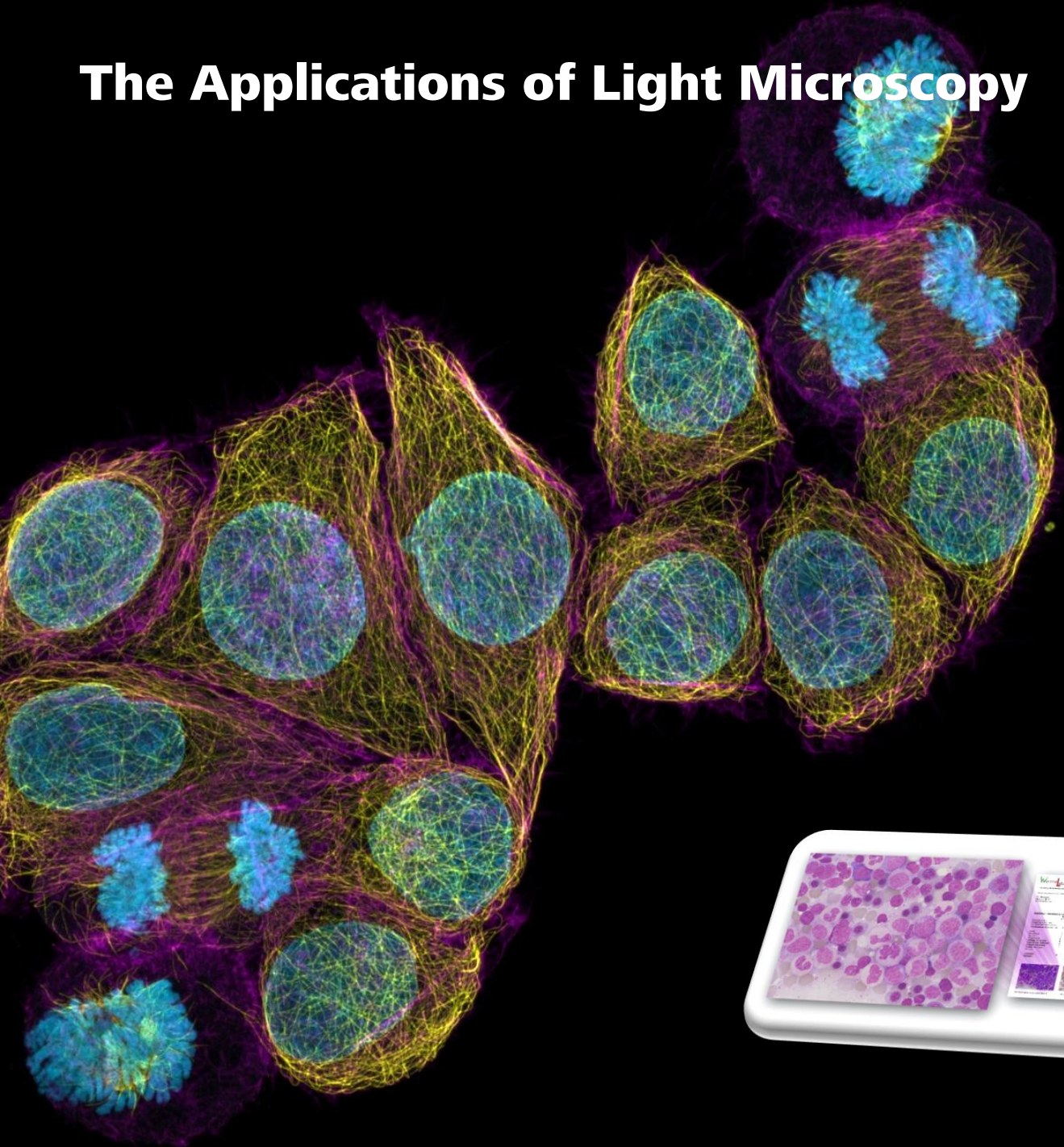

The Applications of Light Microscopy

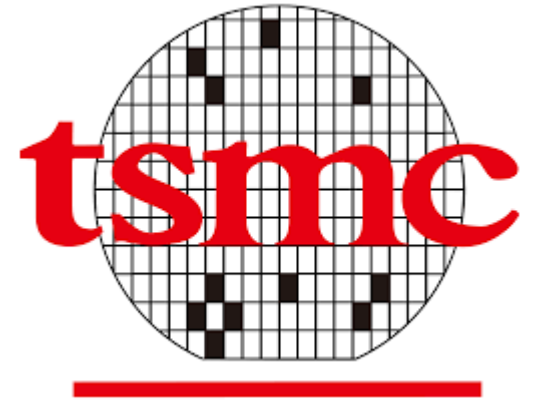

Magnification and Resolution

- Magnification? 100x? 1000x? 999999999x?
- Total magnification = **Objective** magnification x **Eyepiece** magnification
- ~**1500x** is the limit of Light Microscopes, magnification above 1500x is meaningless
- Why?.

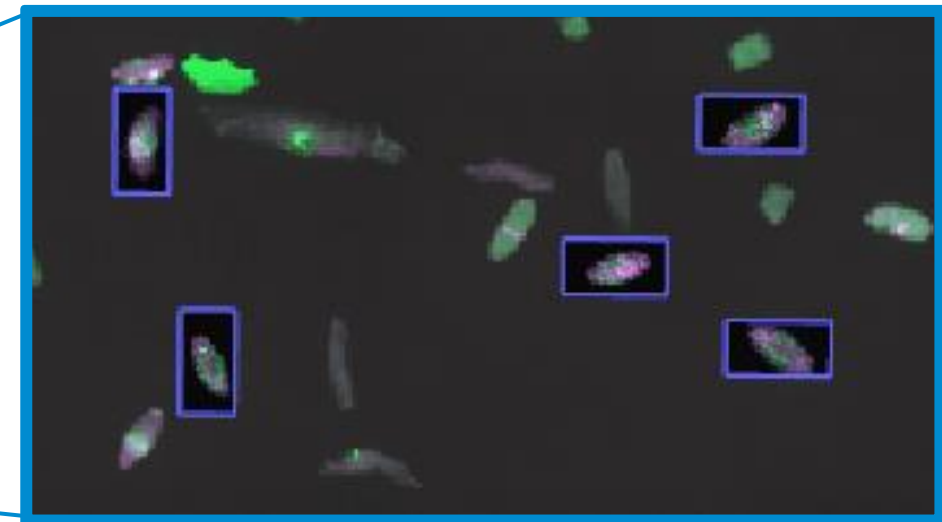
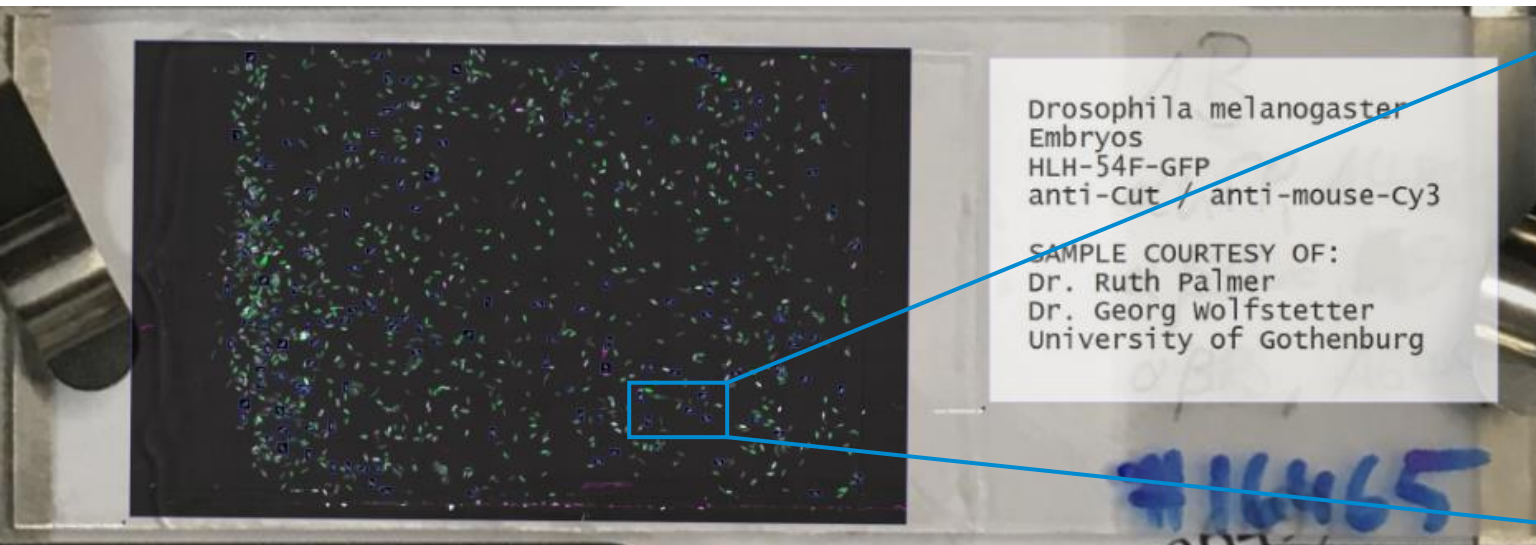
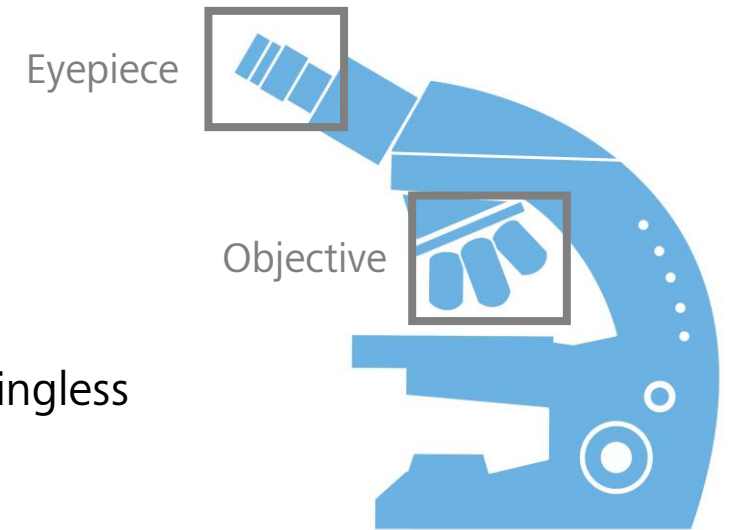

Magnification and Resolution



Magnification and Resolution

Magnification alone is not enough:
Resolution determines what we see.

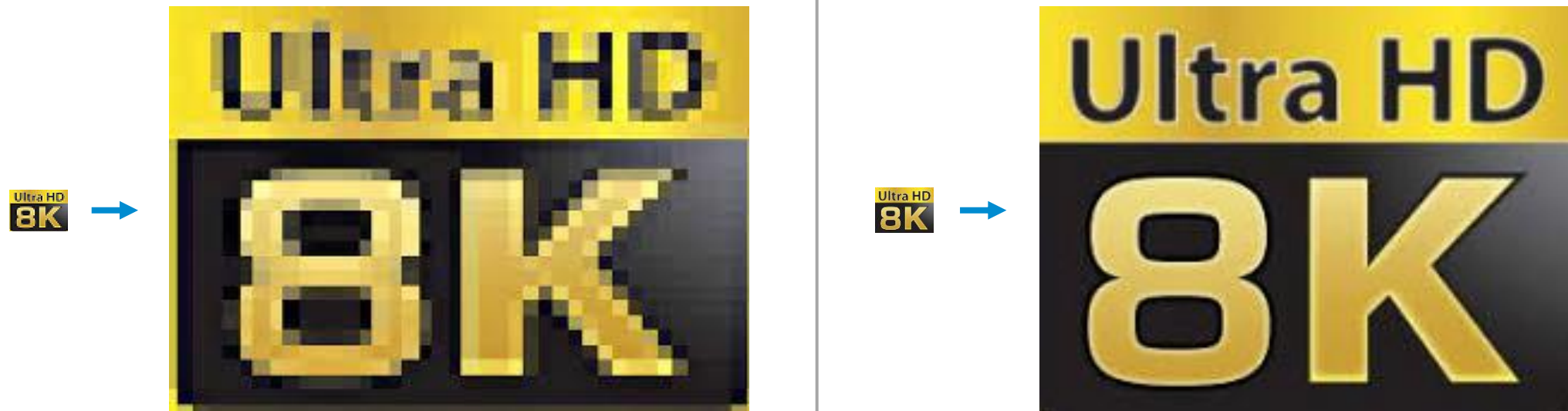

Resolution of Your Eyes

Definition:

The resolution limit is reached, when two point-like objects can not be imaged as two distinct structures anymore.

The **distance** between the objects is called the resolution limit.

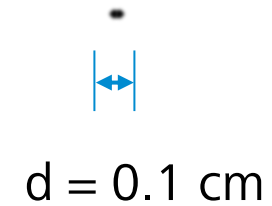
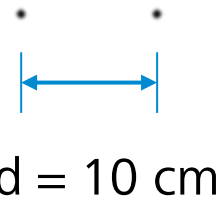

Resolution of Microscopes

Definition:

The resolution limit is reached, when two point-like objects can not be imaged as two distinct structures anymore.

The **distance** between the objects is called the resolution limit.



$$d = 10 \mu\text{m}$$

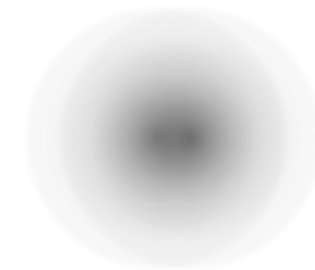

$$d = 0.1 \mu\text{m}$$

Diffraction Limited Resolution

Rayleigh criterion

$$d_0 = \frac{1.22\lambda}{N.A._{obj.} + N.A._{Cond}}$$

or more simply

$$d_0 = \frac{\lambda}{2N.A.}$$

Abbe limit

$$d_0 = \frac{\lambda}{2N.A.}$$

λ = wavelength of light, e.g. 550 nm (green)

The resolution of light microscope $d_0 = 200 \sim 300$ nm

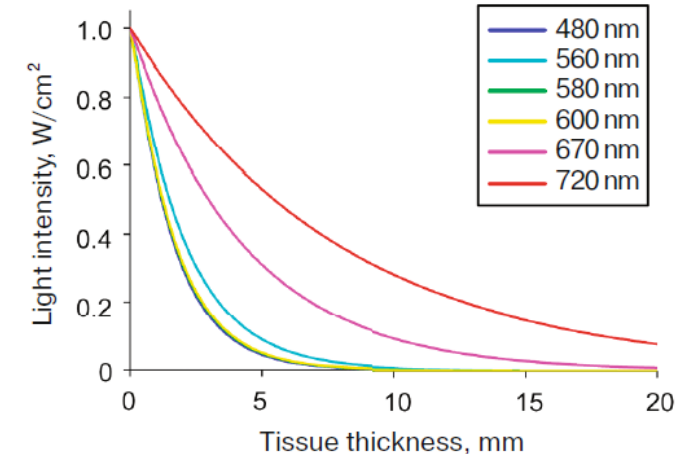
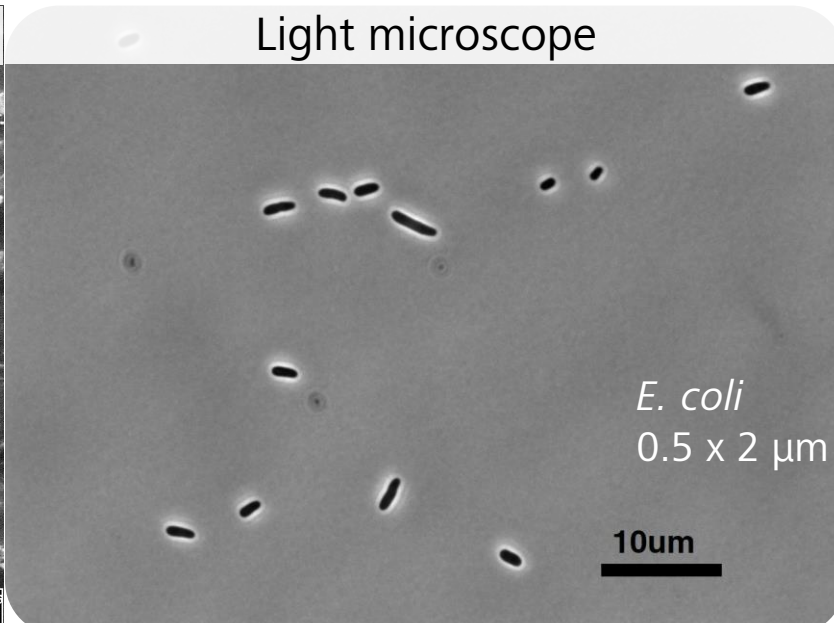
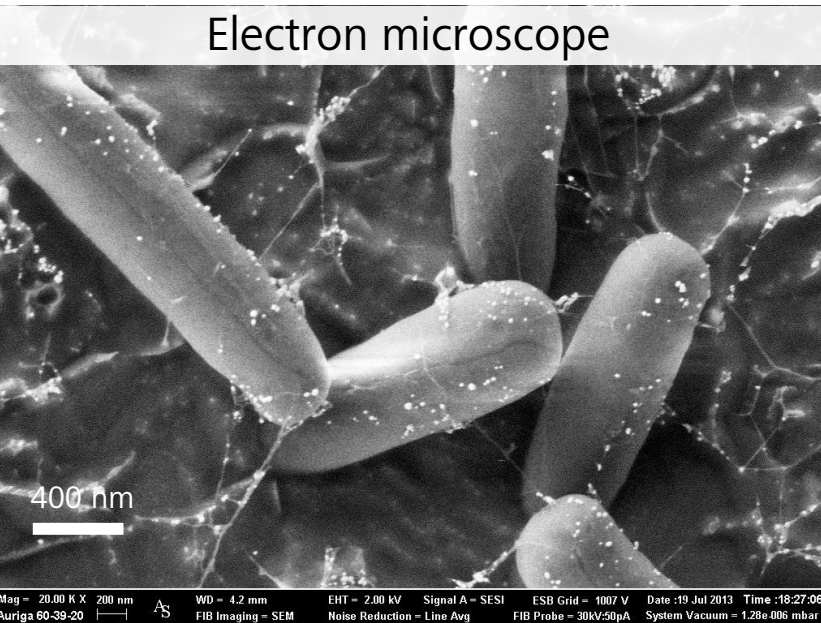
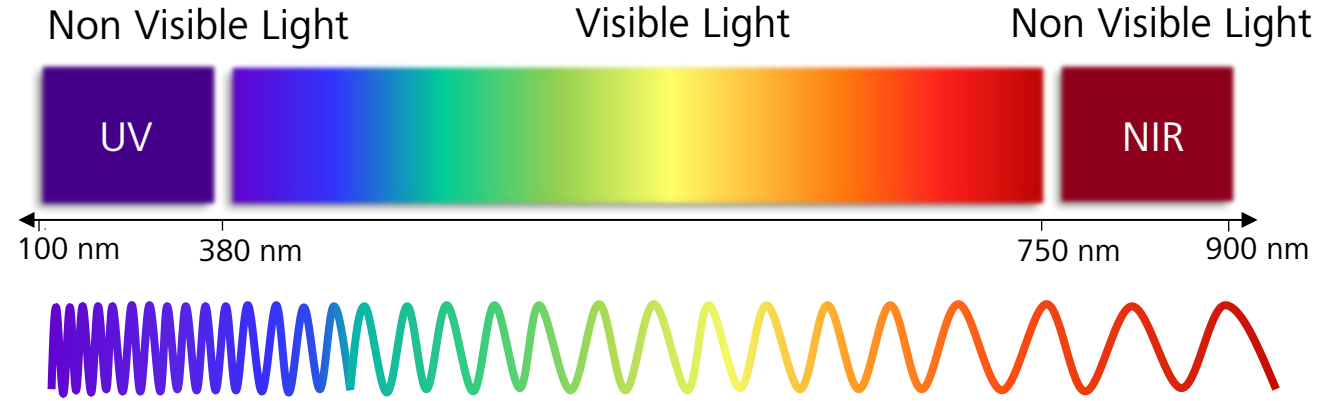
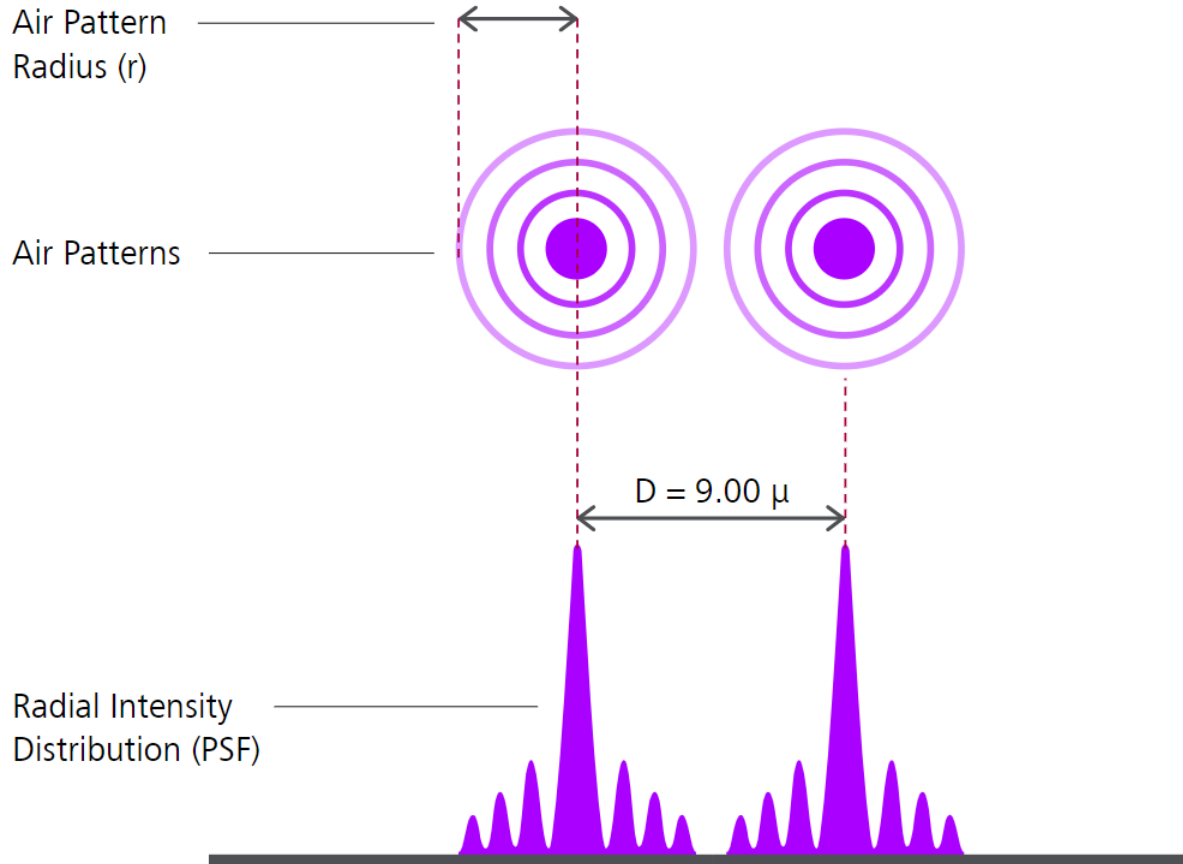

Image adapted from Karasev *et al.*, 2019

Longer wavelength being able to travel deeper into tissue

Resolution – Wavelength

400 nm



700 nm

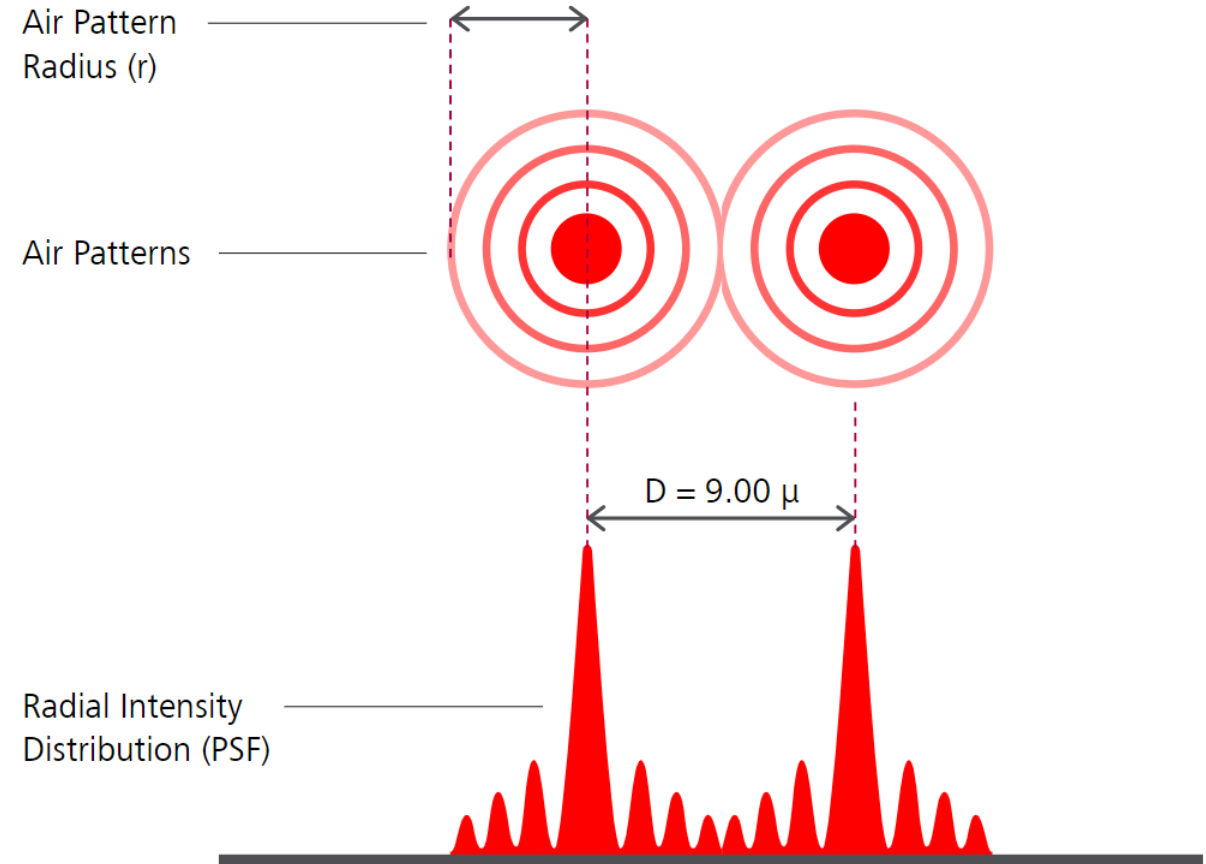

Resolution – N.A.



0.1

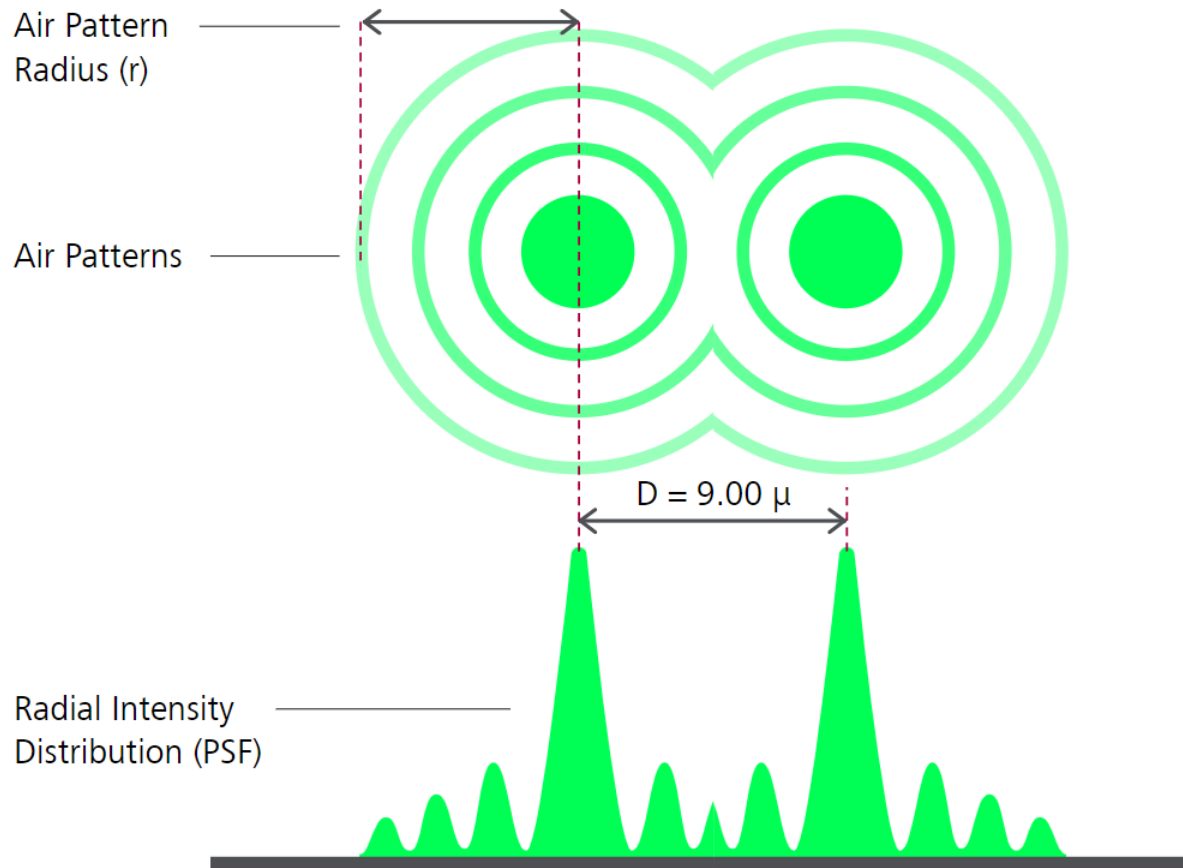

0.36

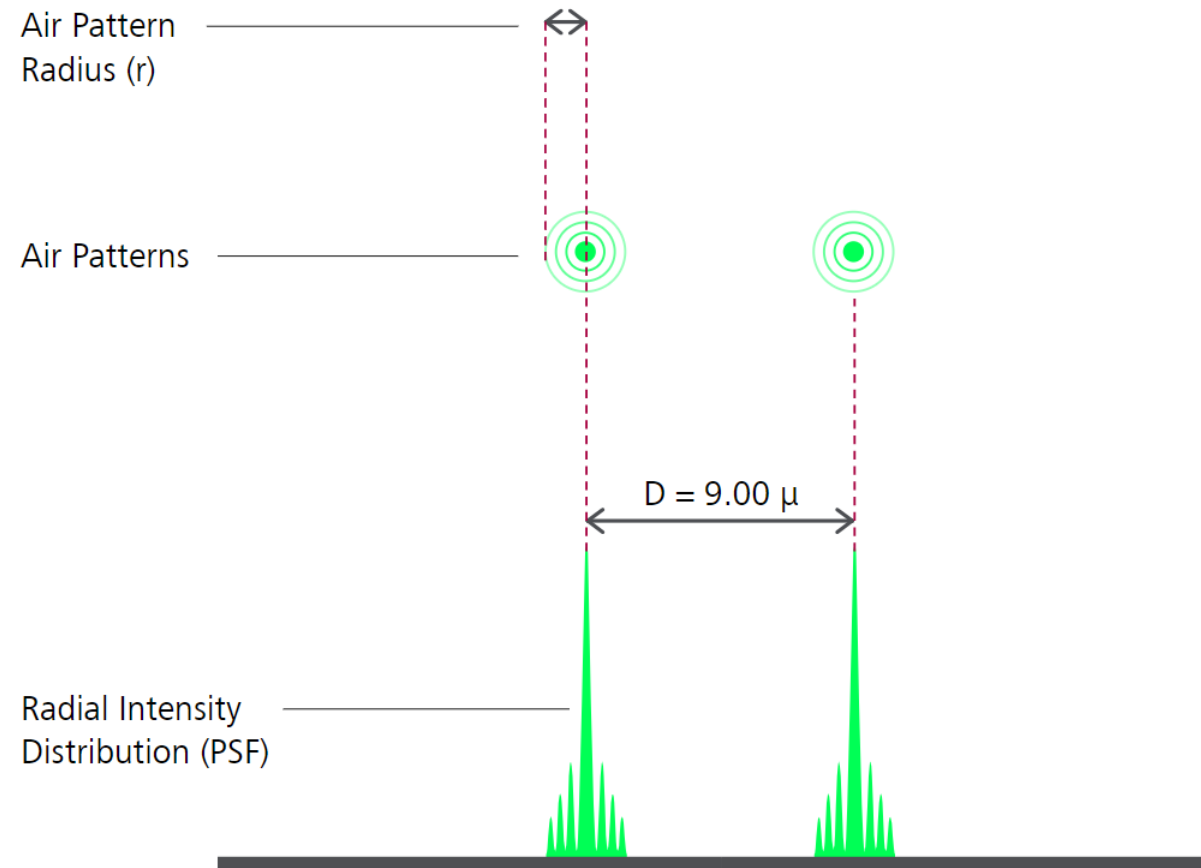

Resolution – N.A.

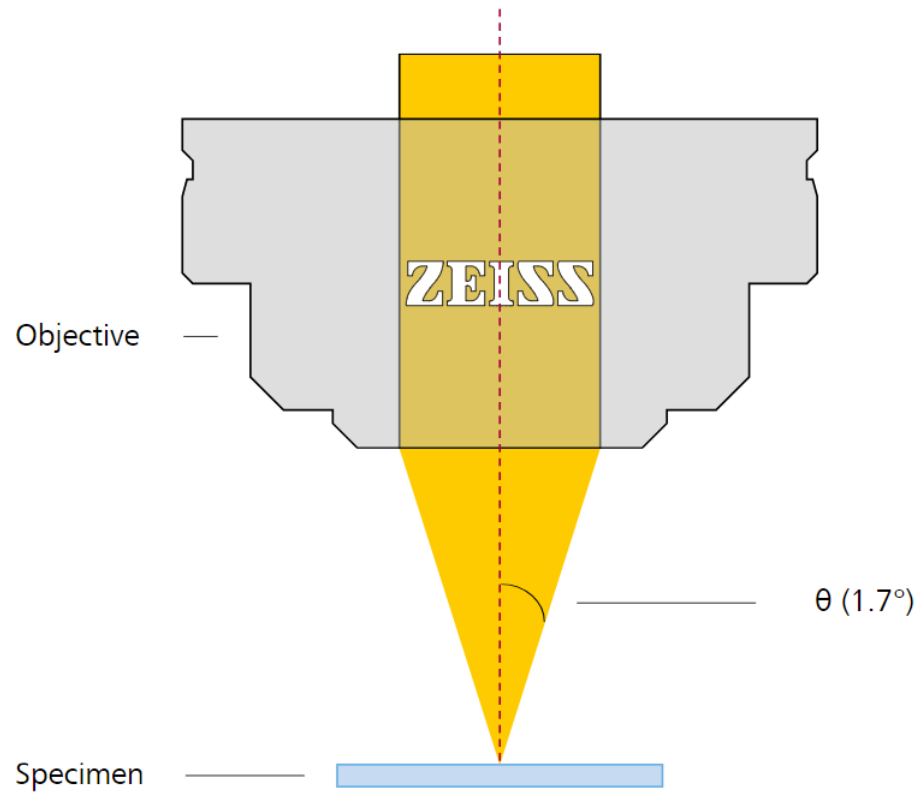

Numerical Aperture



$$\text{Numerical Aperture (NA)} = n \cdot \sin \theta$$

N.A. determines the brightness and resolution of an image formed by an objective



Resolution – N.A.

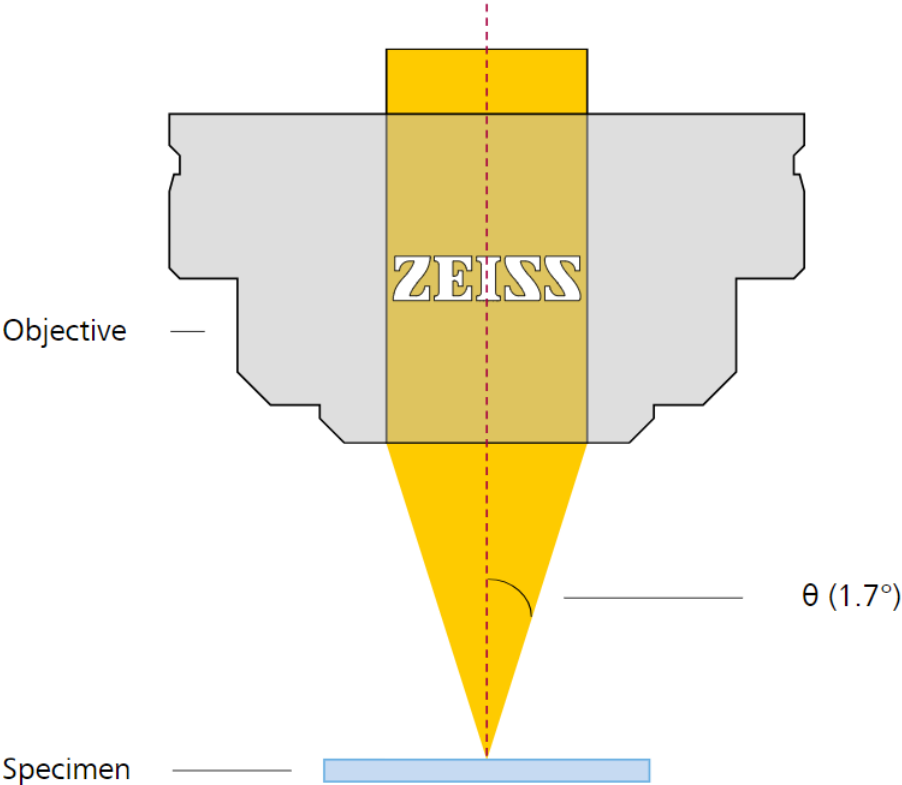

Numerical Aperture

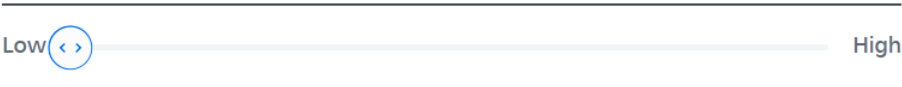

Higher NA offers

- 😊 Better resolution & brighter image
- 😞 Reduced working distance & sensitive to spherical aberration

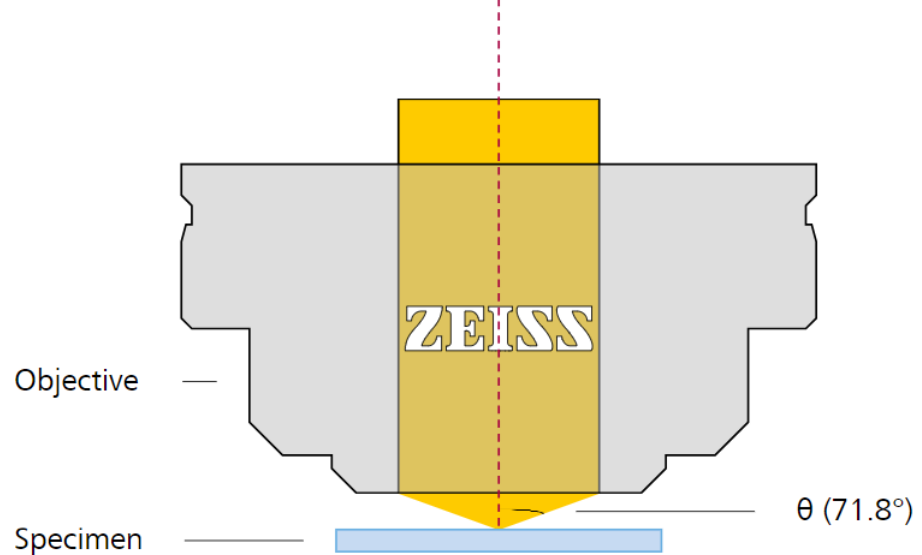

Numerical Aperture

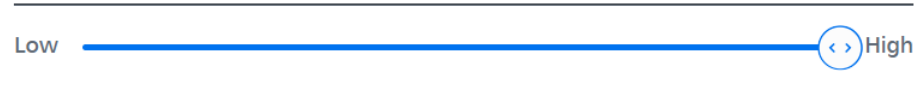

Immersion & Refractive Index

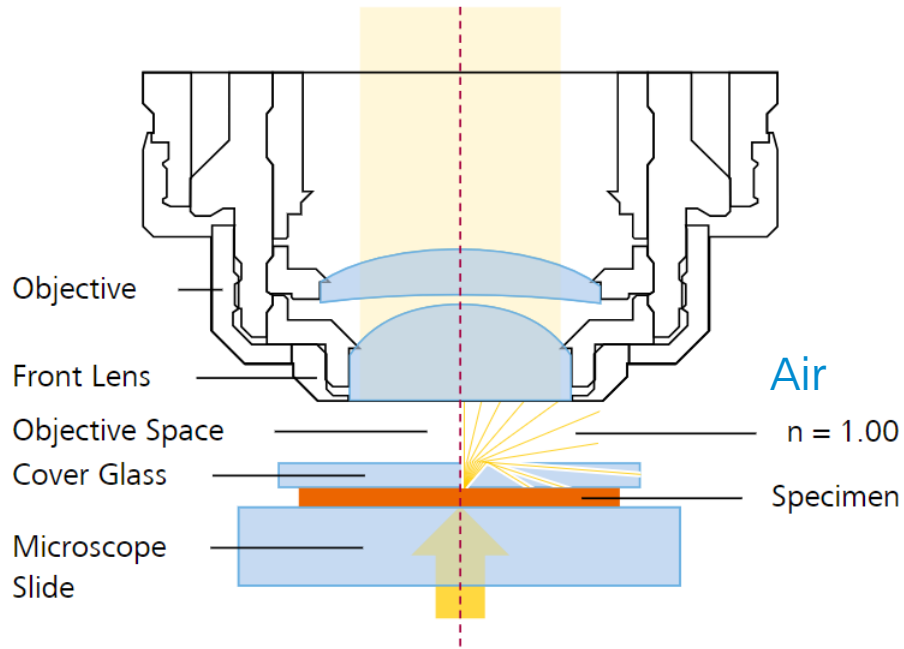

Refractive Index (n)

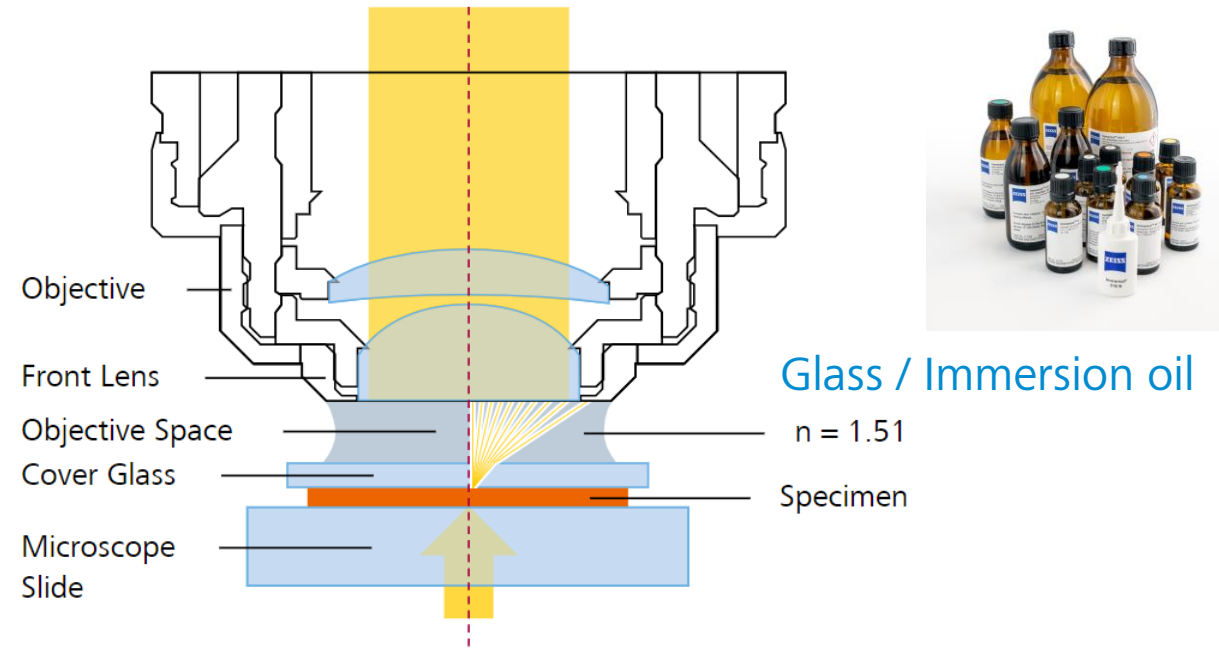

Refractive Index (n)



Higher NA + Immersion = Higher Resolution

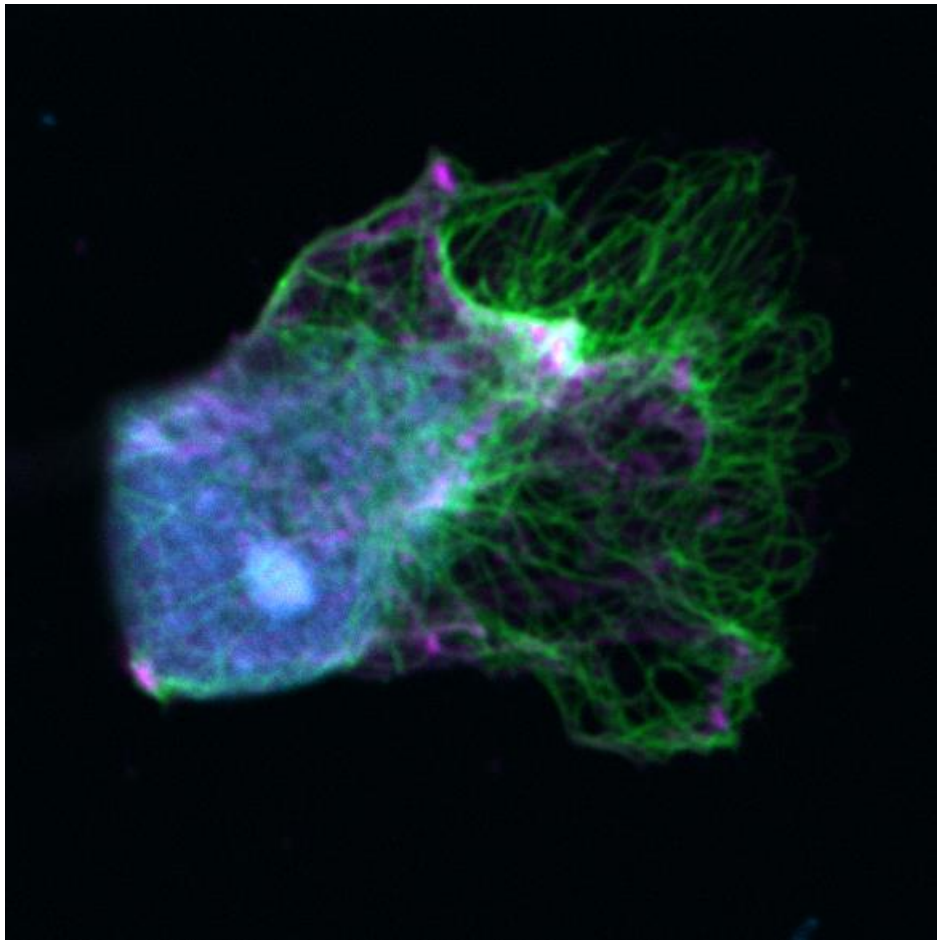

40x / 0.95 air

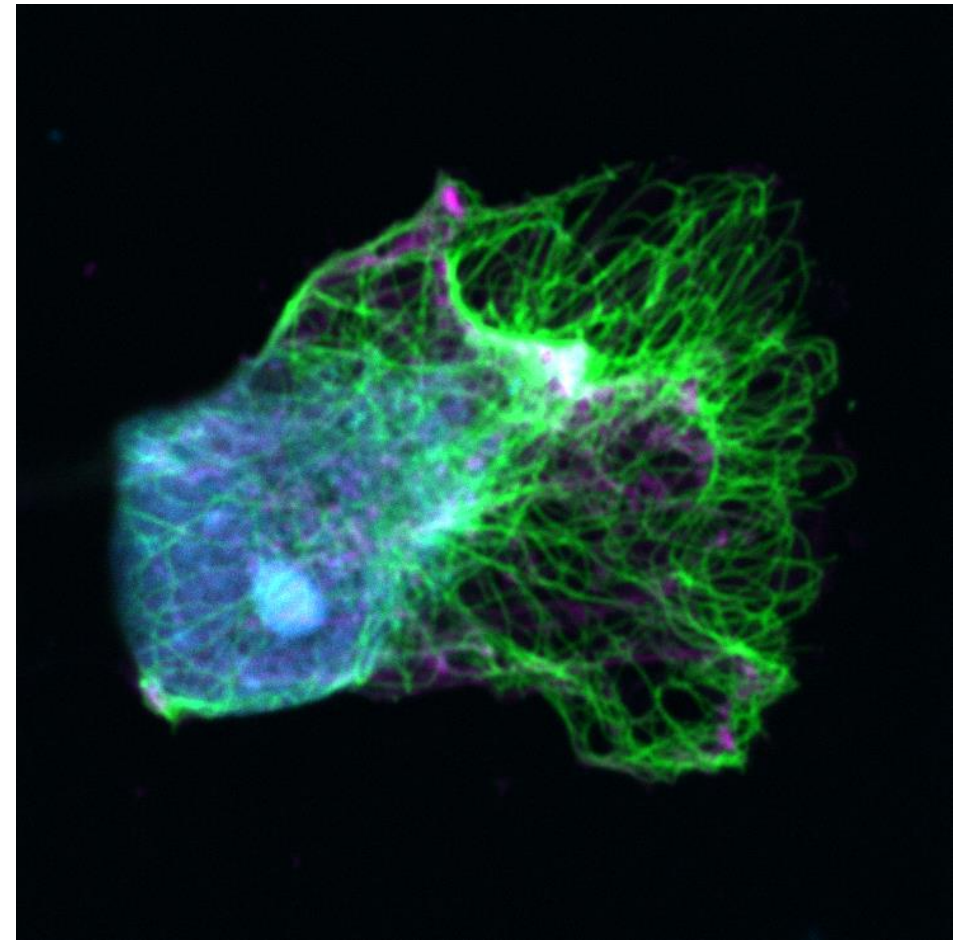

40x / 1.2 water

Higher NA + Immersion = Higher Resolution

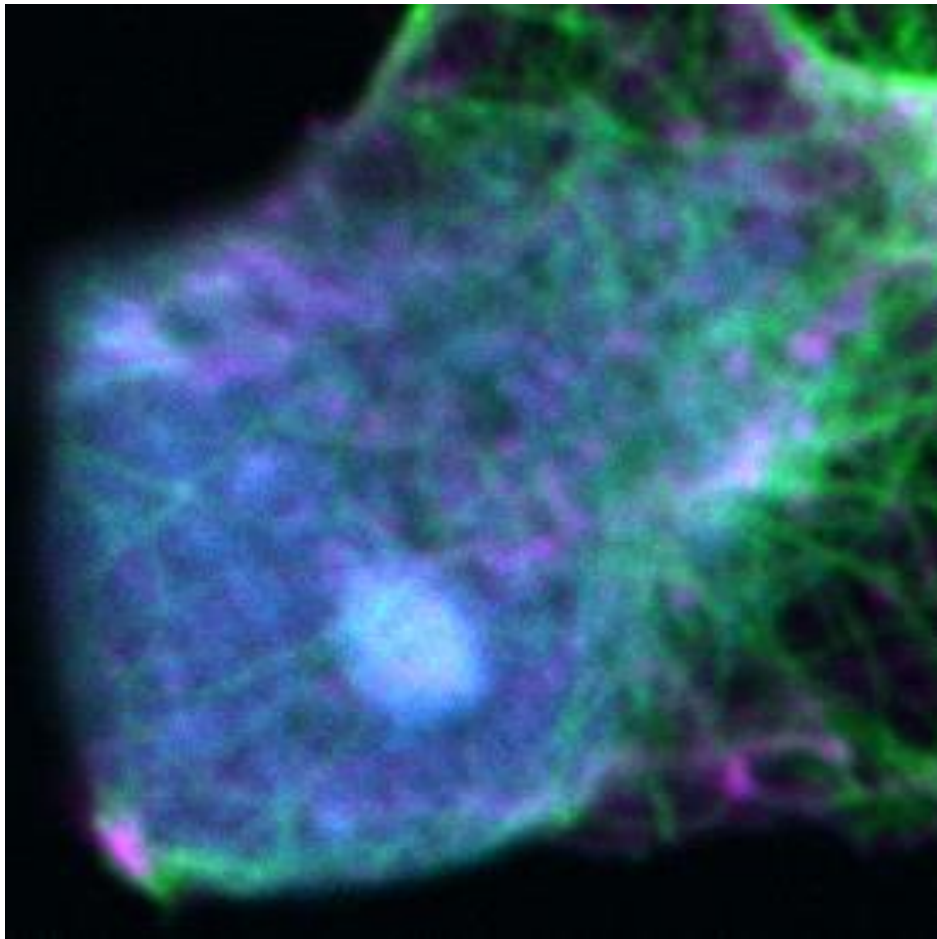

40x / 0.95 air

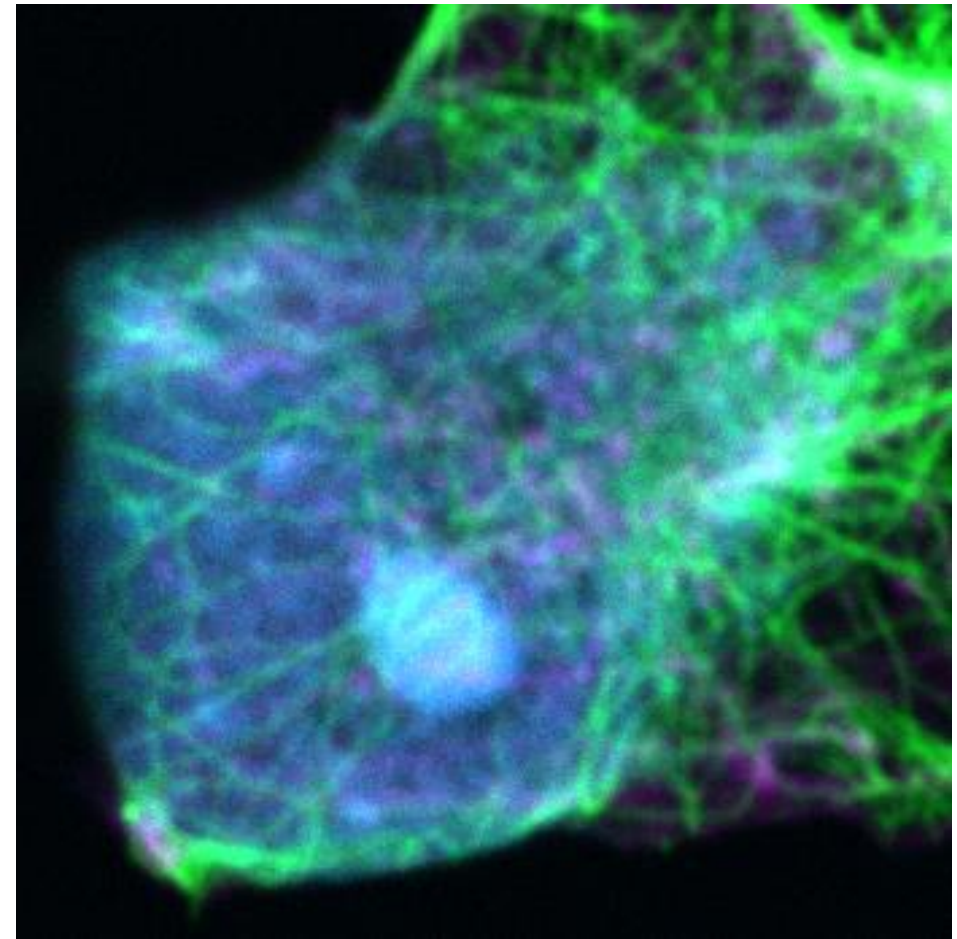

40x / 1.2 water

Immersion Objectives



Commercial Products for Cleaning Microscope Optical Systems



Figure 4

Techniques for Clearing Optical Surfaces

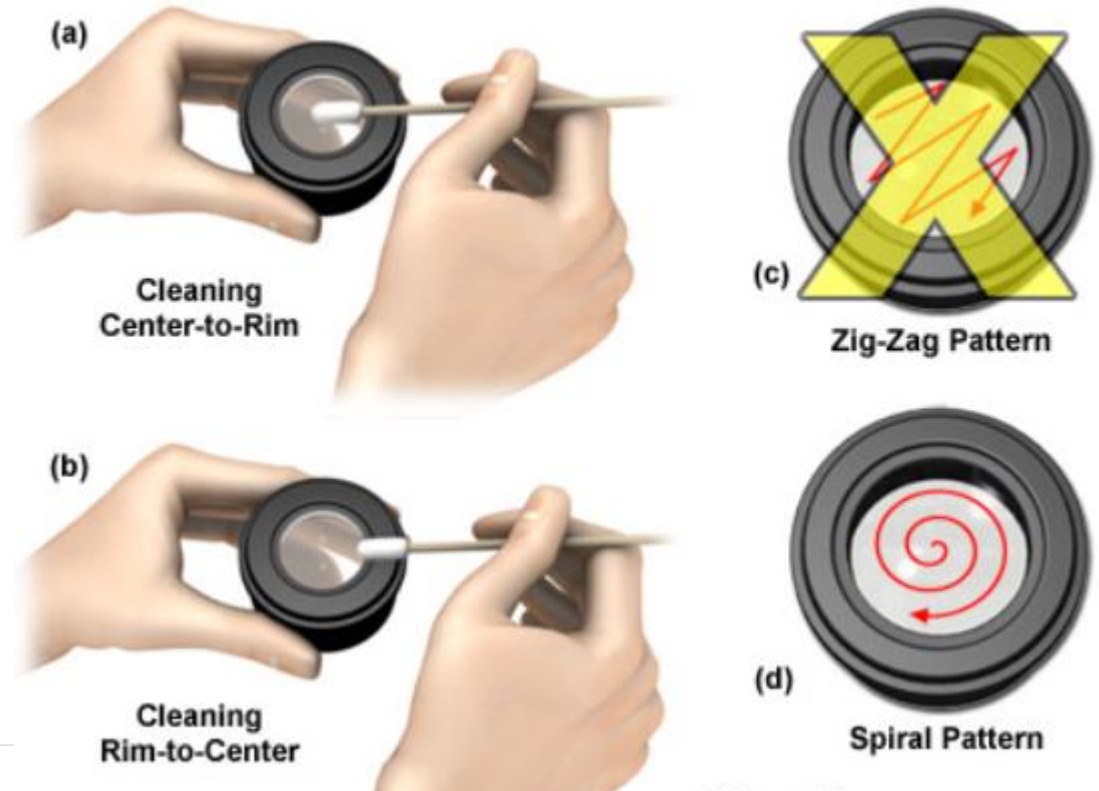

Immersion & Refractive Index



Sample objective only / might differ according to settings

Mechanical Correction Collar ×

- Cover glass thickness correction
- Different Immersion (Oil, Glyc, Water)
- Different Temperature
- Adjusting an Iris Diaphragm



Multi-Immersion objectives (**Live Cell Imaging**-objectives) can be used when working with different immersion media (oil, glycerol, water)

Sample Carrier Thickness

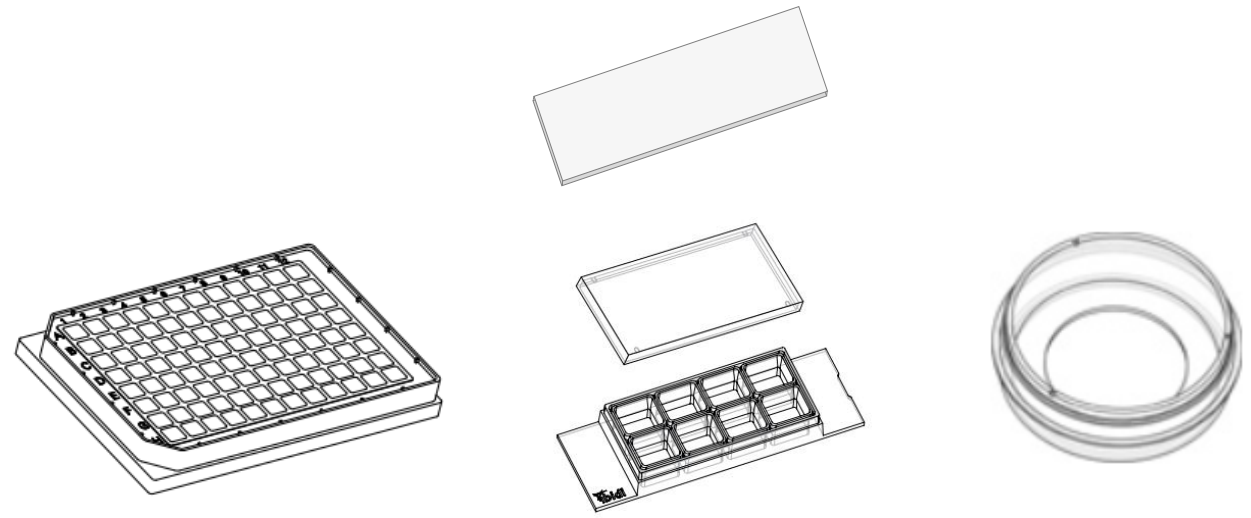
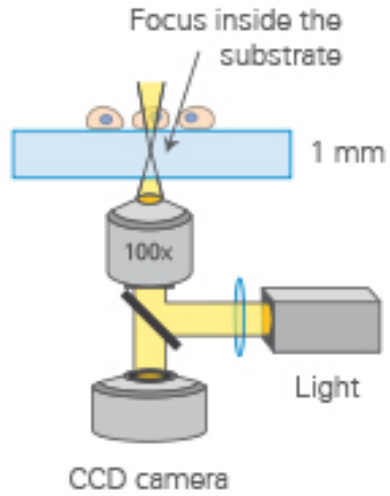
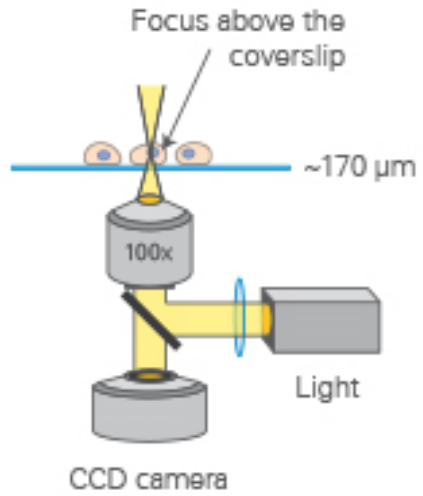

Front View

Magnification, numerical aperture:

- Immersion medium (water/silicone oil/glycerine/oil)
- Adjustable cover-glass correction
- Contrast method

Cover-glass thickness (mm)

ICS optics: ∞

- ICS optics
- Cover-glass thicknesses: 0-0.17
- OFN: Objective field number 18

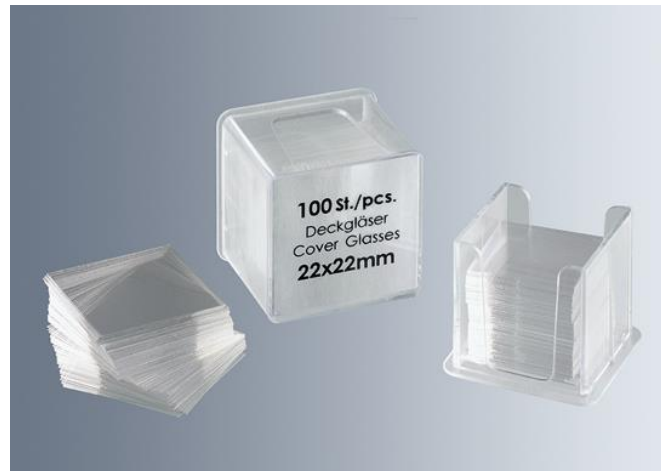

Thickness no. 1 (0.13-0.16 mm)

Thickness no. 1.5 (0.16-0.19 mm)

Thickness no. 1.5H (0.165-0.175 mm)

Contrast Methods

Sample Carrier Thickness

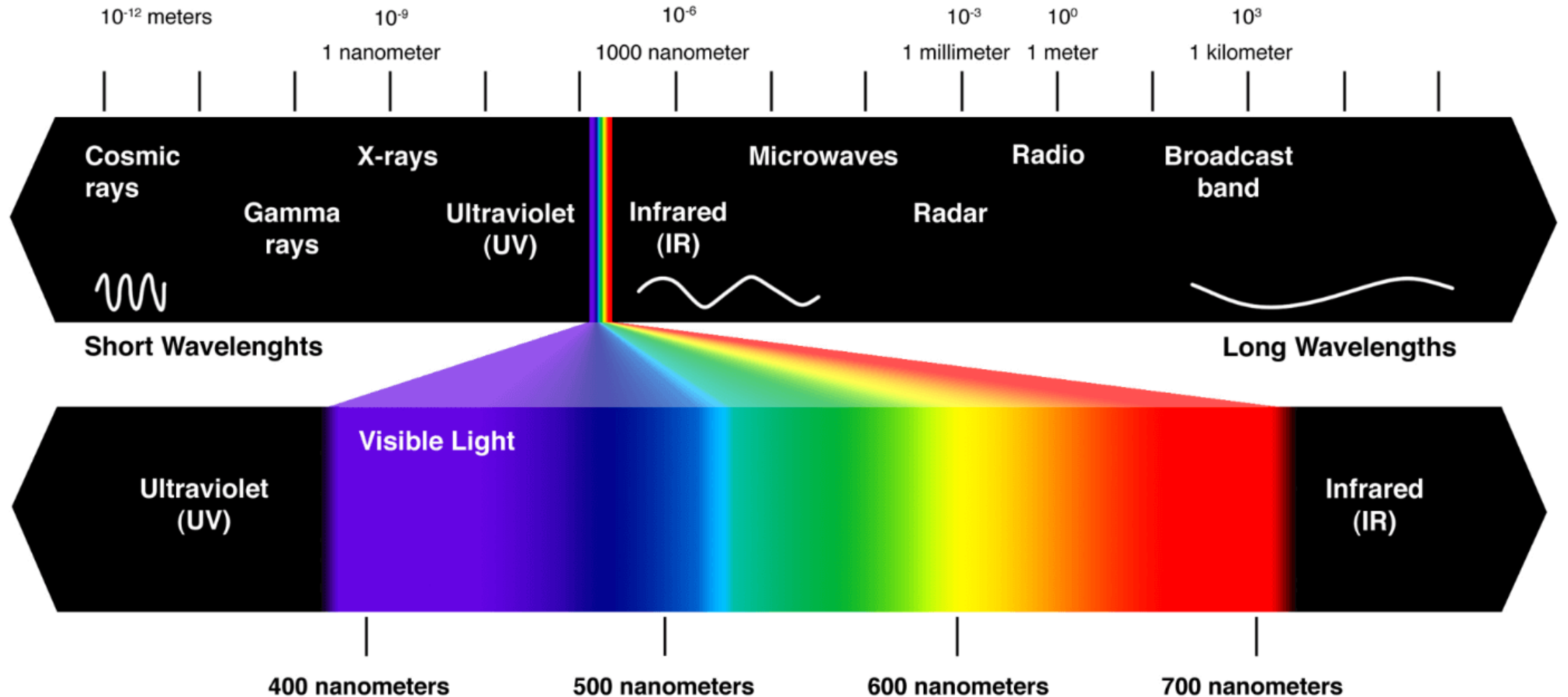

Contrast Methods of Transmitted Light

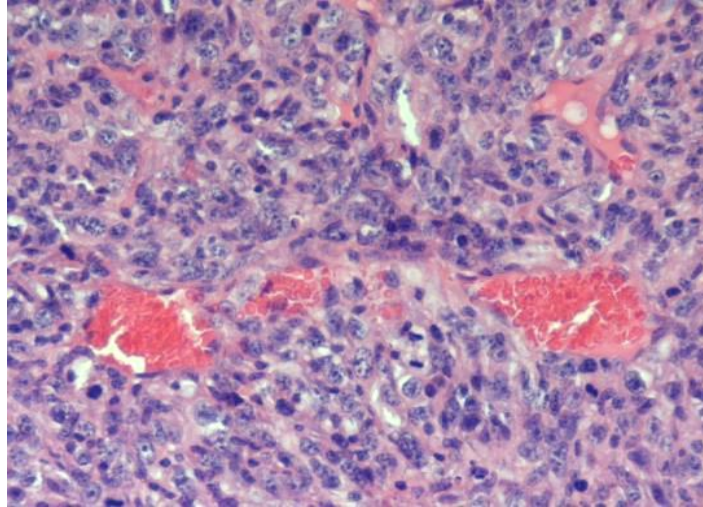

Brightfield
Colorful samples
Widefield microscopes

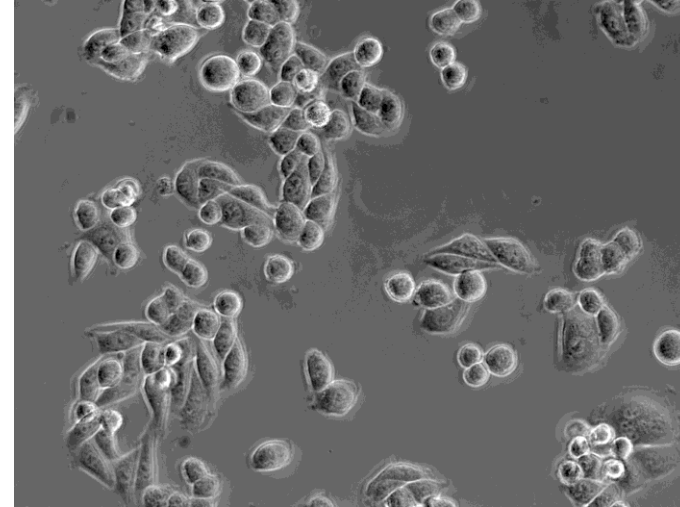

Phase contrast
Colorless samples
Widefield microscopes

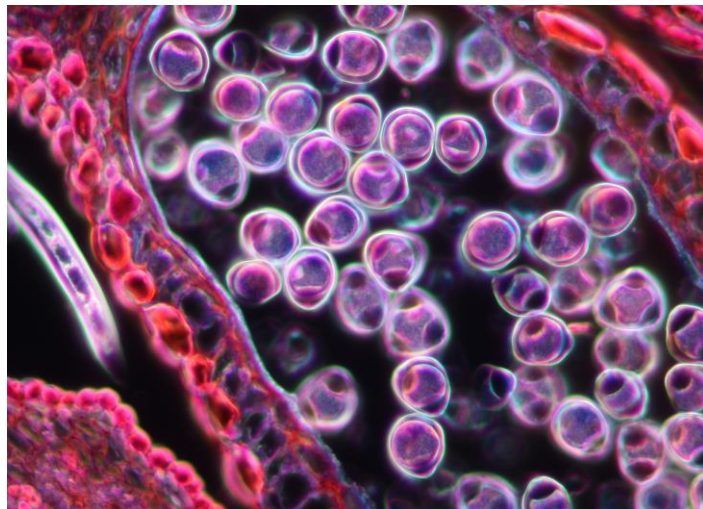

Dark field
Translucent samples
Widefield microscopes

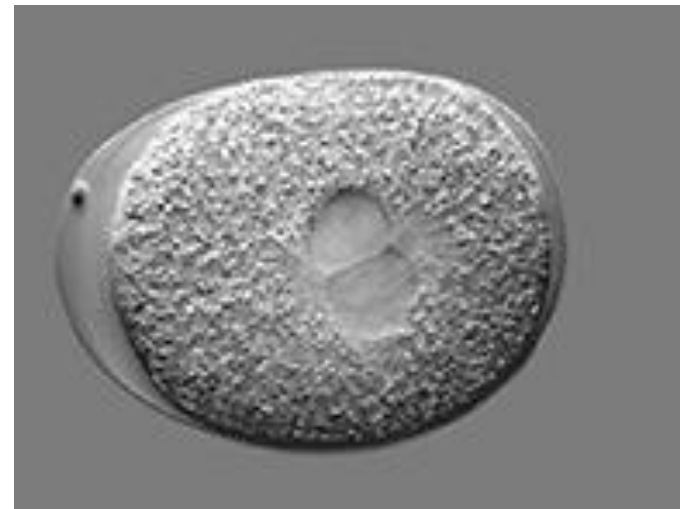

DIC (Differential Interference Contrast)
Colorless samples
Widefield / confocal
microscopes

Phase Contrast vs DIC

Ph (Phase Contrast)

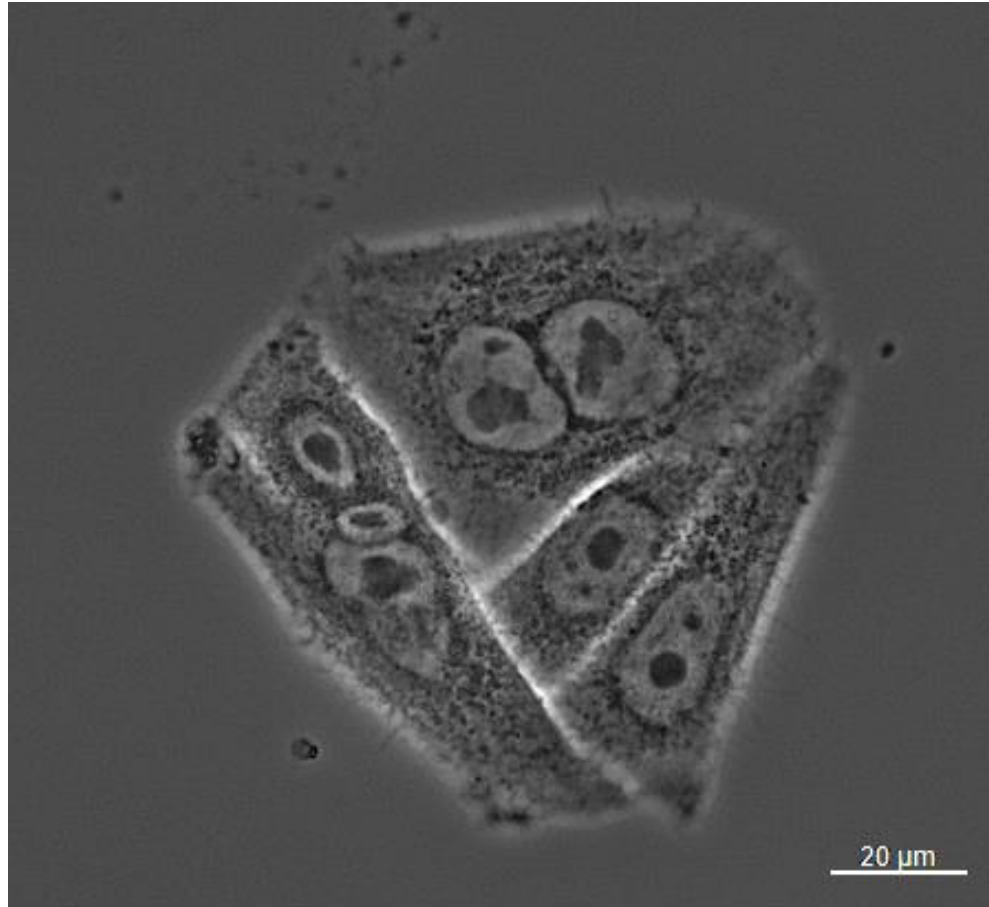

DIC (Differential Interference Contrast)

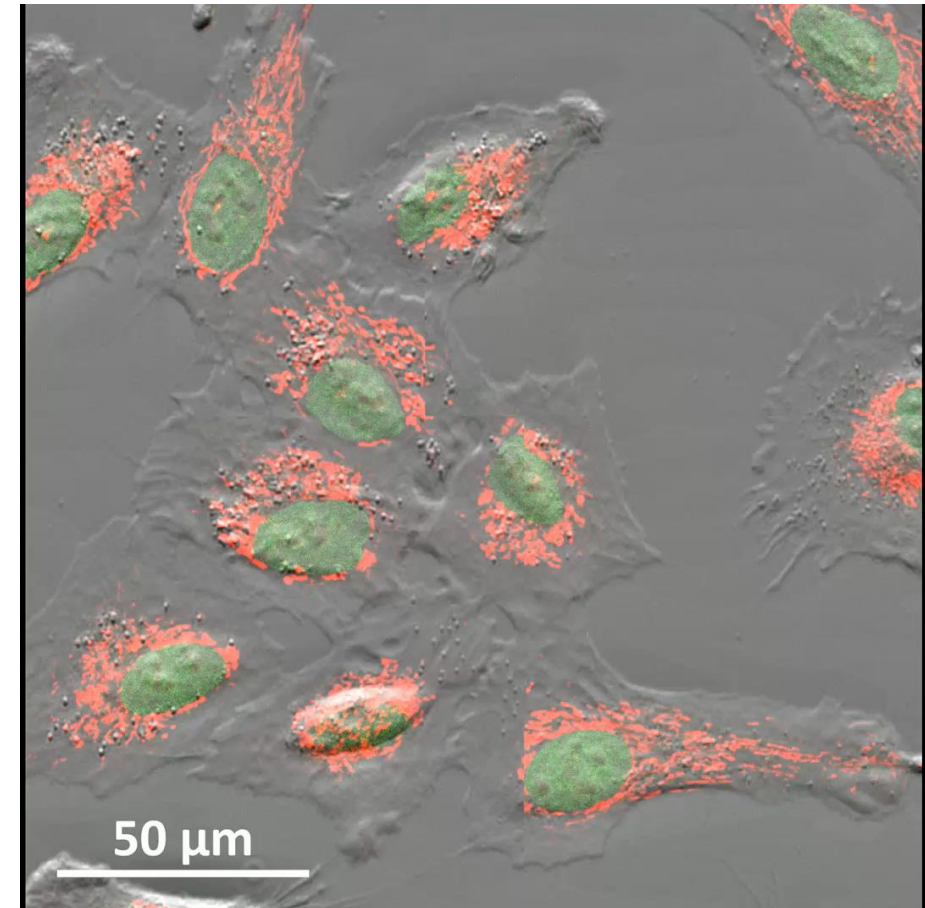

Phase Contrast vs DIC

DIC

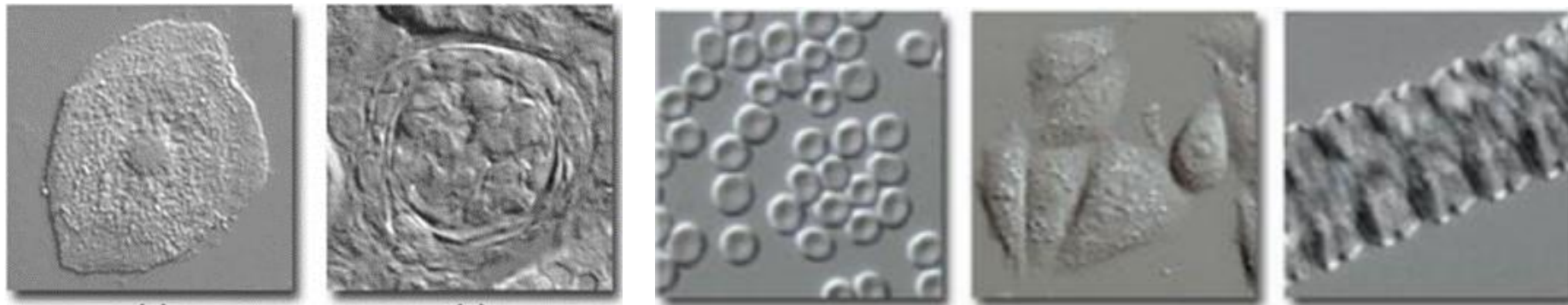

(a)

(c)

Phase

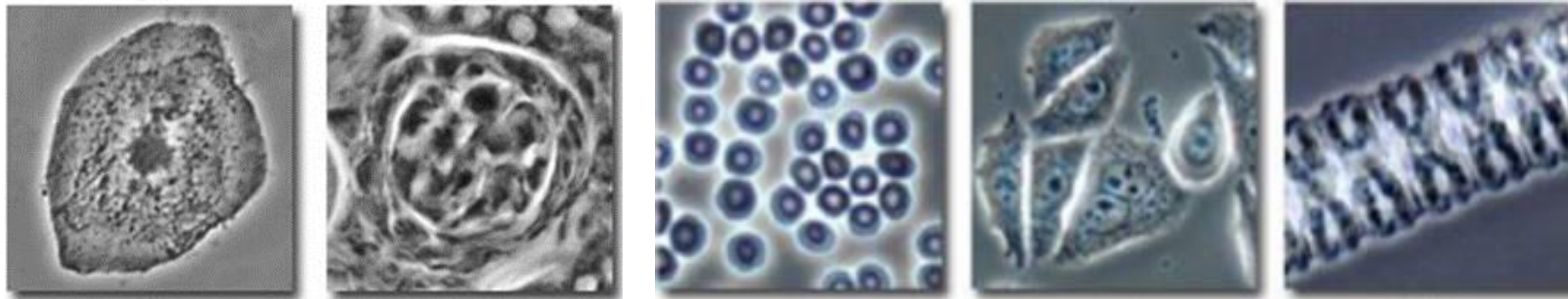

Fluorescence Microscopy

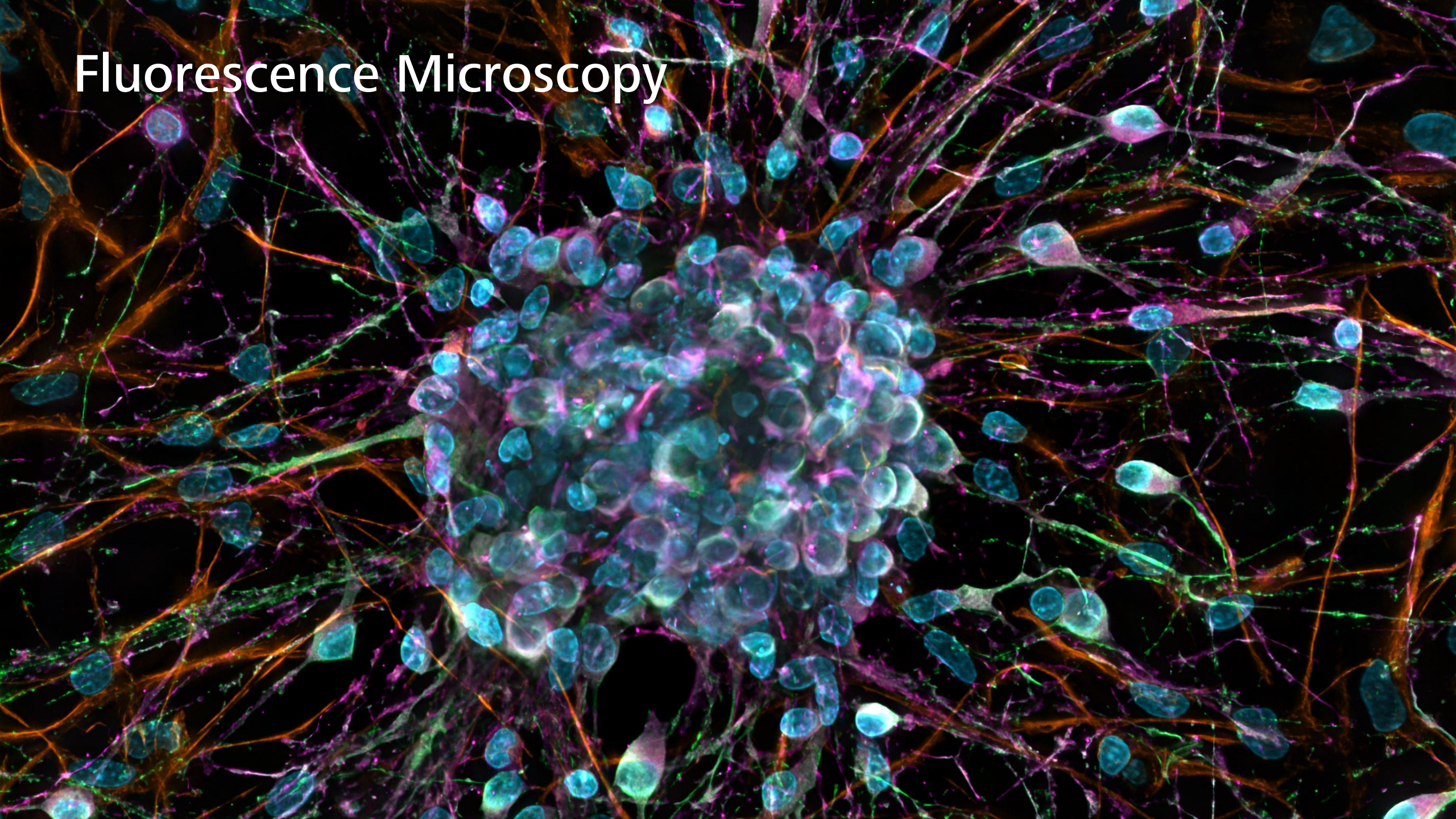

Fluorescence Contrast (FL)

- Specific, precision to molecule level
- Multiple staining
- High resolution
- 4D imaging
- Fluorescence bleaching ☹️
- Gene transfection, fluorescent dyes
- Fluorescence filters
- Fluorescent light sources

The Nobel Prize in Chemistry 2008

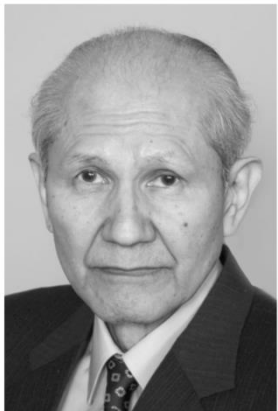

© The Nobel Foundation. Photo: U. Montan
Osamu Shimomura

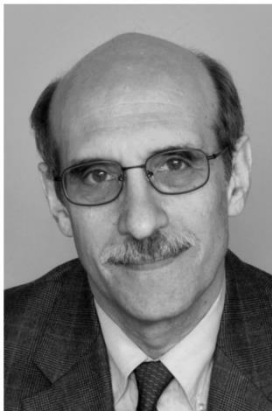

© The Nobel Foundation. Photo: U. Montan
Martin Chalfie



© The Nobel Foundation. Photo: U. Montan
Roger Y. Tsien

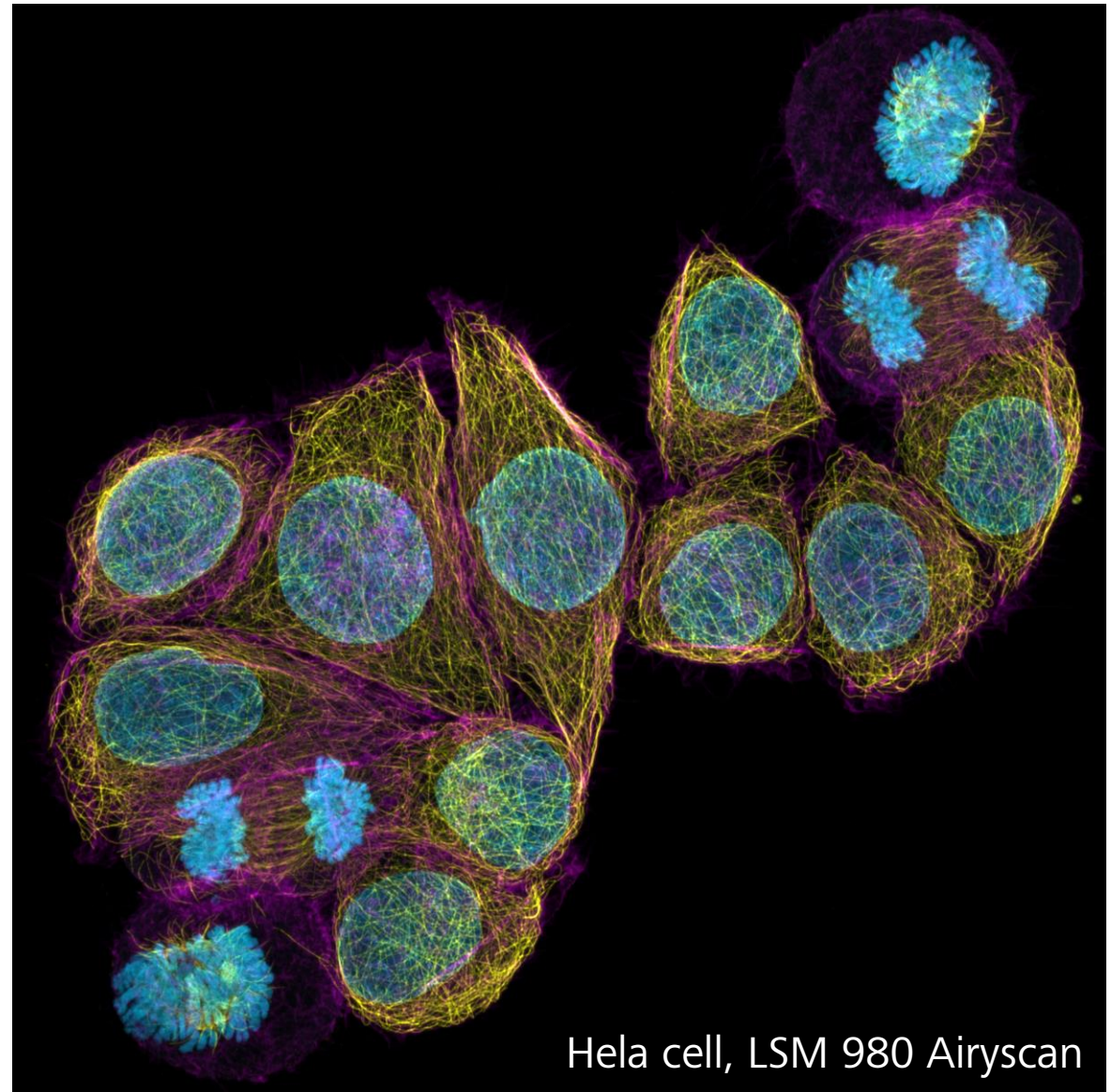

HeLa cell, LSM 980 Airyscan

Fluorescence Contrast (FL)

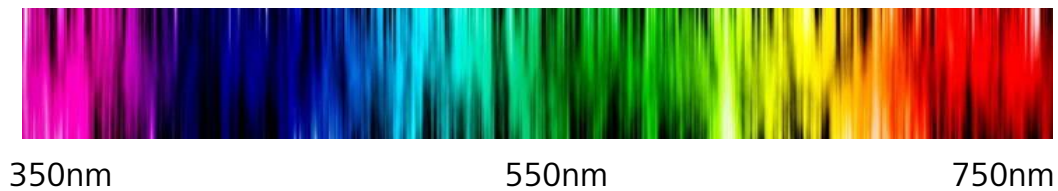
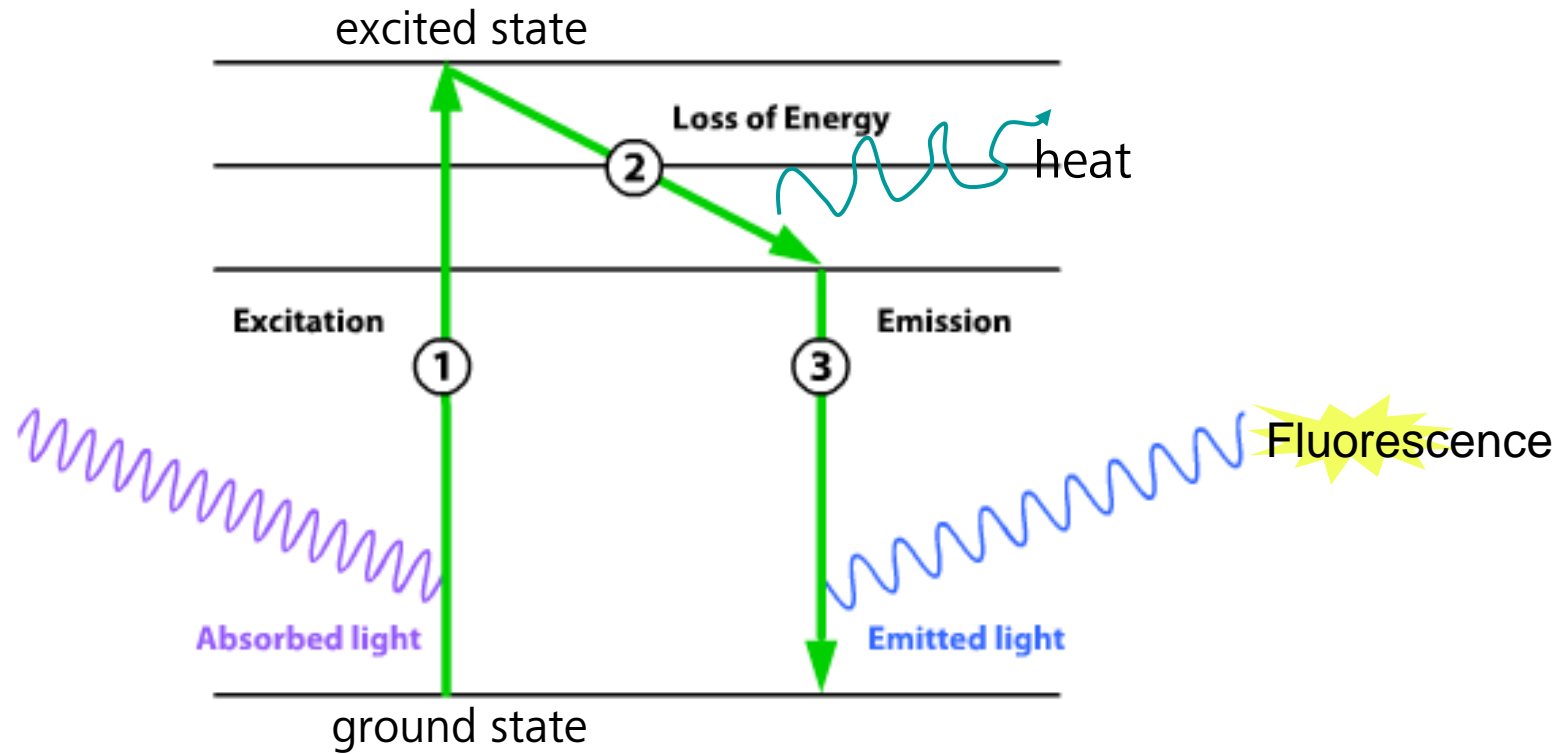

The Filter Sets for Fluorescence Microscopy

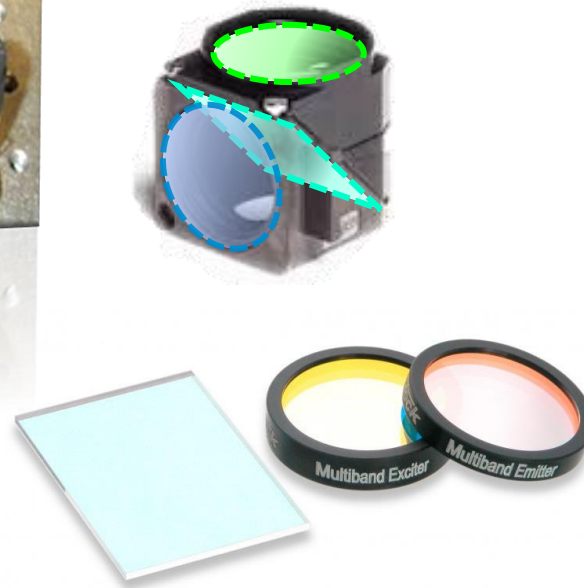

Light Path of Fluorescence Microscopy



Fluorescence Filters

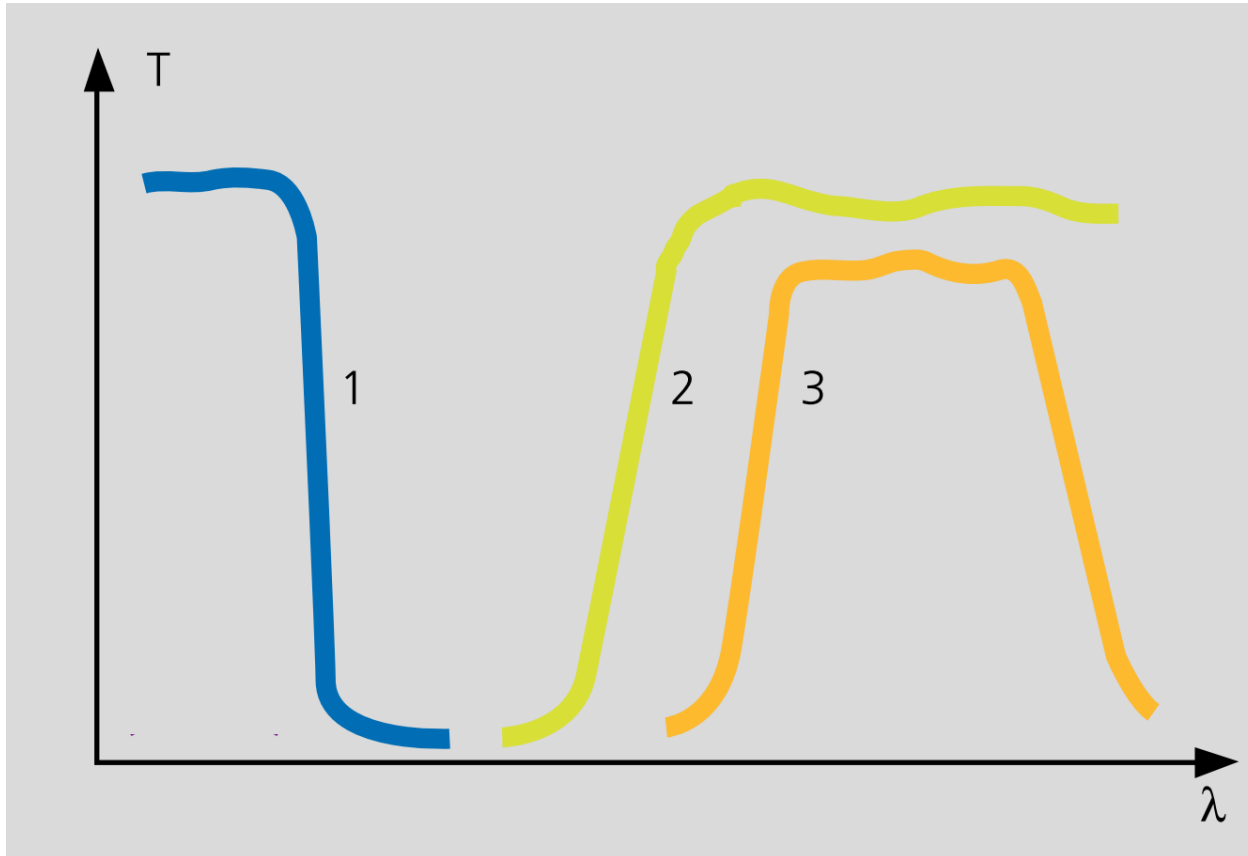

1. Shortpass filter
2. Longpass filter
3. Bandpass filter

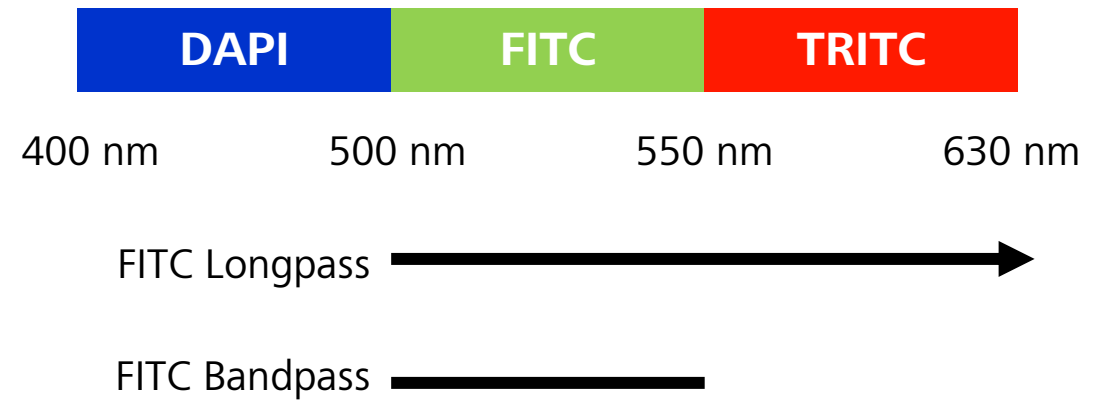

Fluorescence Filter



Fluorescence filter cube

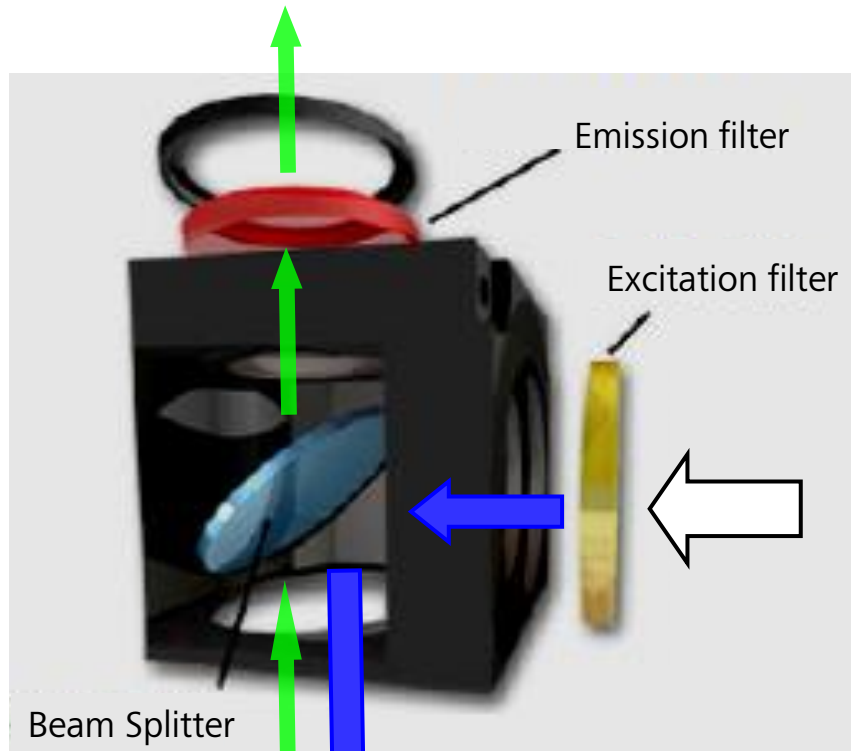

Sample

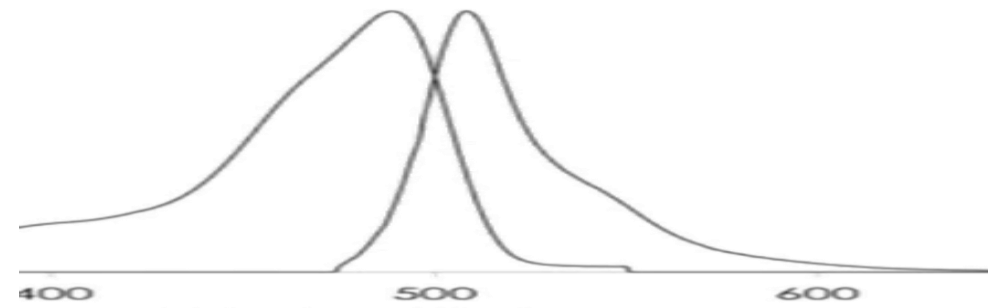

EGFP (Ex. 488 nm, Em. 507 nm)

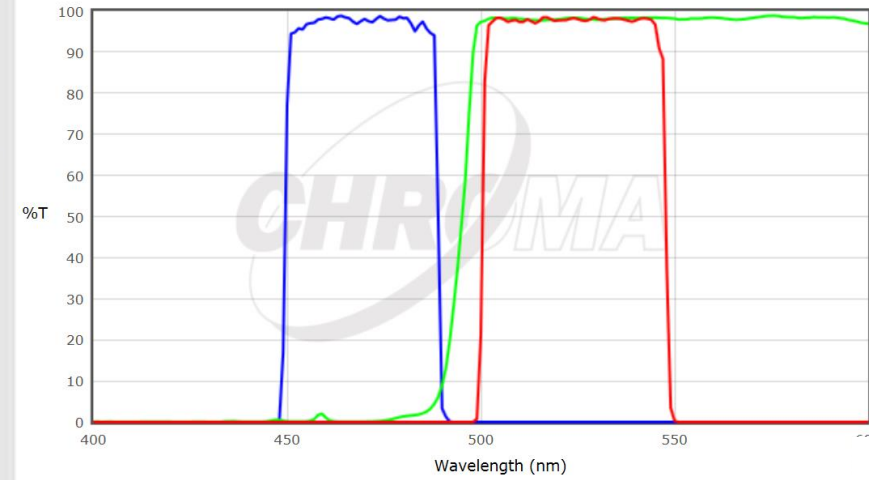

FILTERS	TYPE
● ET470/40x	EX
● T495lpxr	BS
● ET525/50m	EM

Fluorescence Filter

Fluorescence filter cube

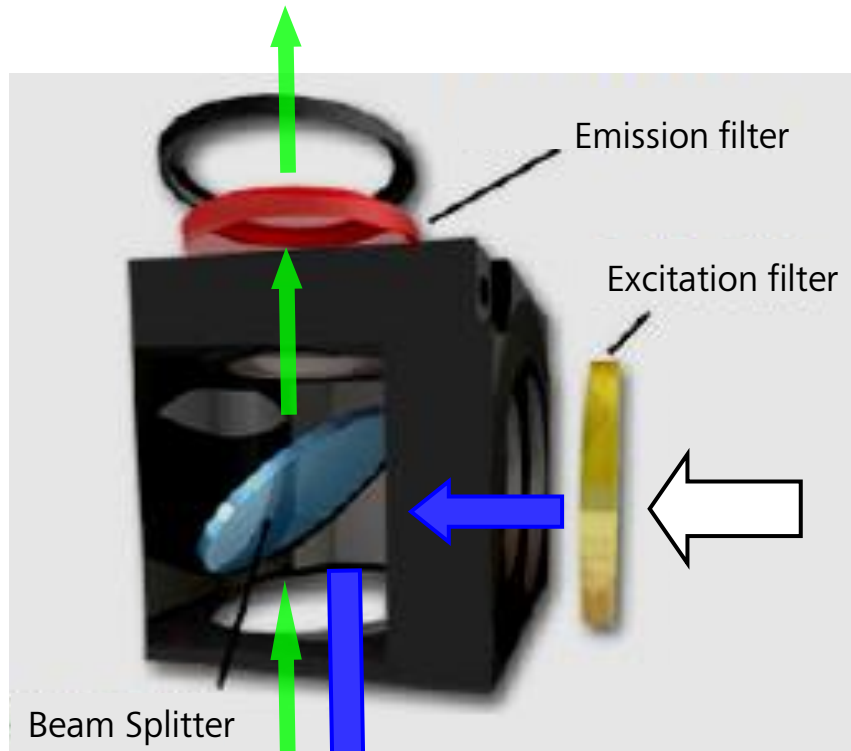

EGFP (Ex. 488 nm, Em. 507 nm)

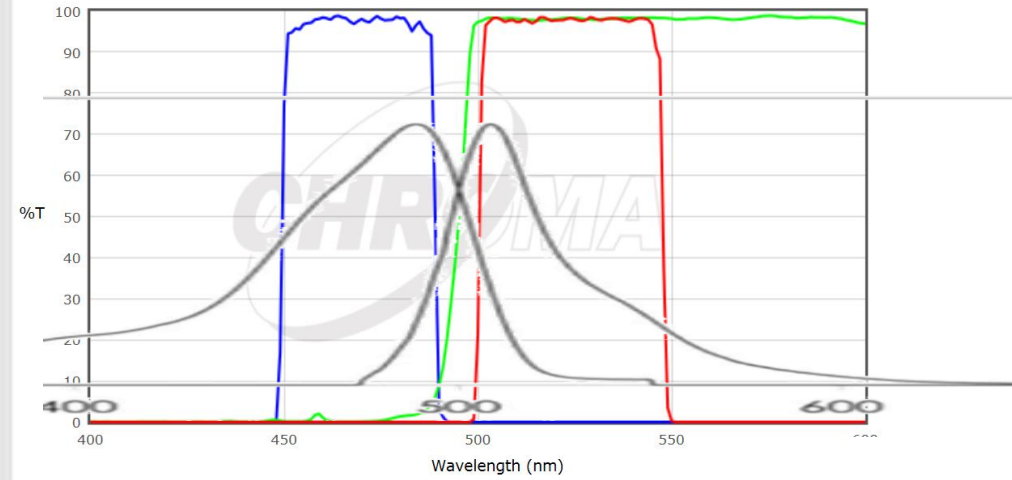

FILTERS	TYPE
● ET470/40x	EX
● T495lpxr	BS
● ET525/50m	EM

Sample

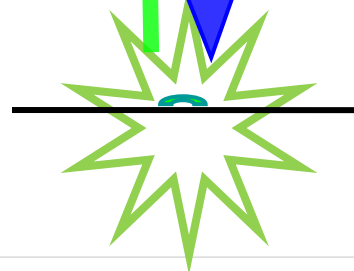

Spectra Viewer

Fluorochromes Sets Parts [Remove All](#)

Current selection (0 of 5)

NUMBER - NAME

- 11014v2 Narrow Blue
- 19000 AT - UV/DAPI Longpass
- 19001 AT - Aqua Longpass
- 19002 AT - GFP/FITC Longpass

[Reload Plot](#)

Fluorochromes

[FITC \(collapse\)](#) [Remove](#) [Add Compatible Sets](#)

PLOT	FILTERS	TYPE	%T-OD	AOI	DATA
<input checked="" type="checkbox"/>	● FITC Excitation Spectra	EX	12.32 T/317nm	0°	ASCII
<input checked="" type="checkbox"/>	● FITC Emission Spectra	EM	0.00 T/317nm	0°	ASCII

Catalog Sets

[49002 \(collapse\)](#) [Remove](#) [Add to cart](#)

PLOT	FILTERS	TYPE	%T-OD	AOI	DATA
<input checked="" type="checkbox"/>	● ET470/40x	EX	0.00 T/317nm	0°	ASCII
<input checked="" type="checkbox"/>	● T495 pxr	BS	0.00 T/317nm	45°	ASCII
<input checked="" type="checkbox"/>	● ET525/50m	EM	0.00 T/317nm	0°	ASCII

%T OD

300 to 600

[update](#)

[reset](#)

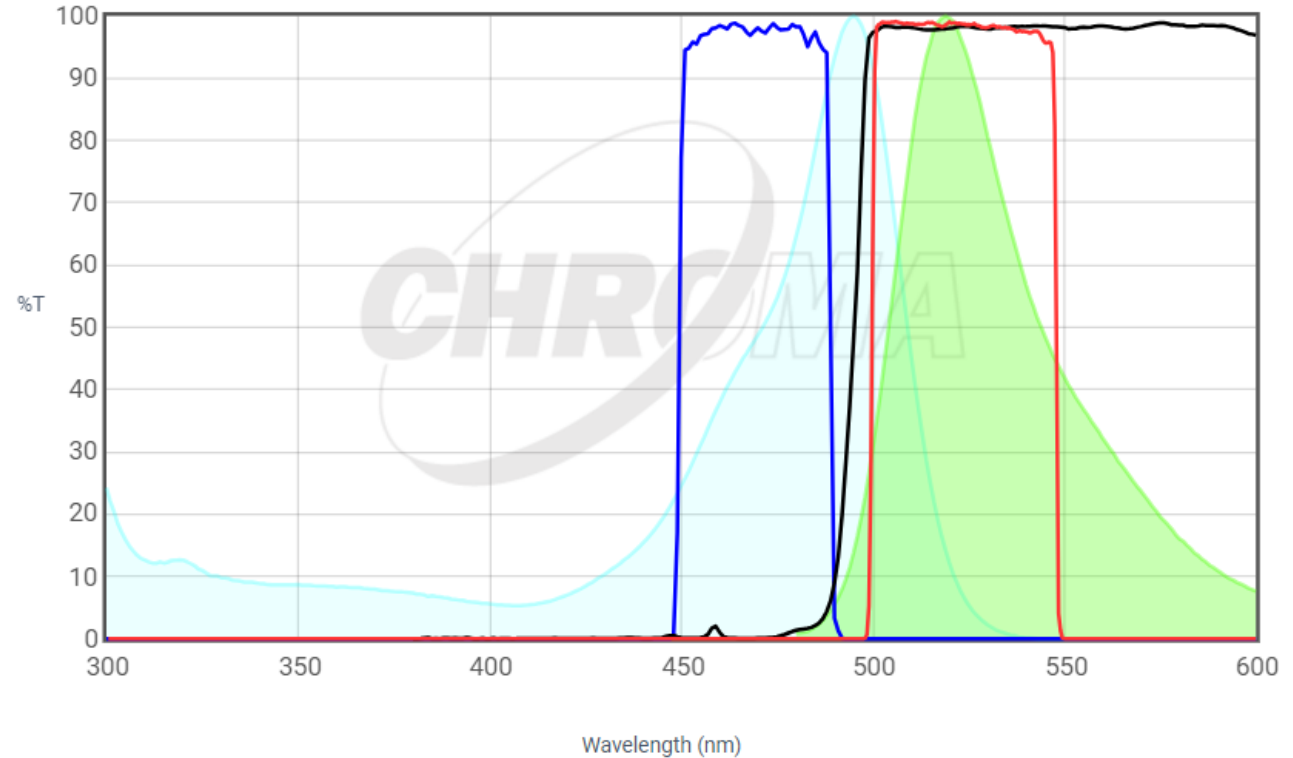

All transmission and blocking (OD) data are actual, measured spectra of representative production lots. Spectra varies slightly from lot to lot. Optical density values in excess of 6 may appear noisy because such evaluations push the resolution limit of low light level measurements.

Keep the Context of Your Experiments

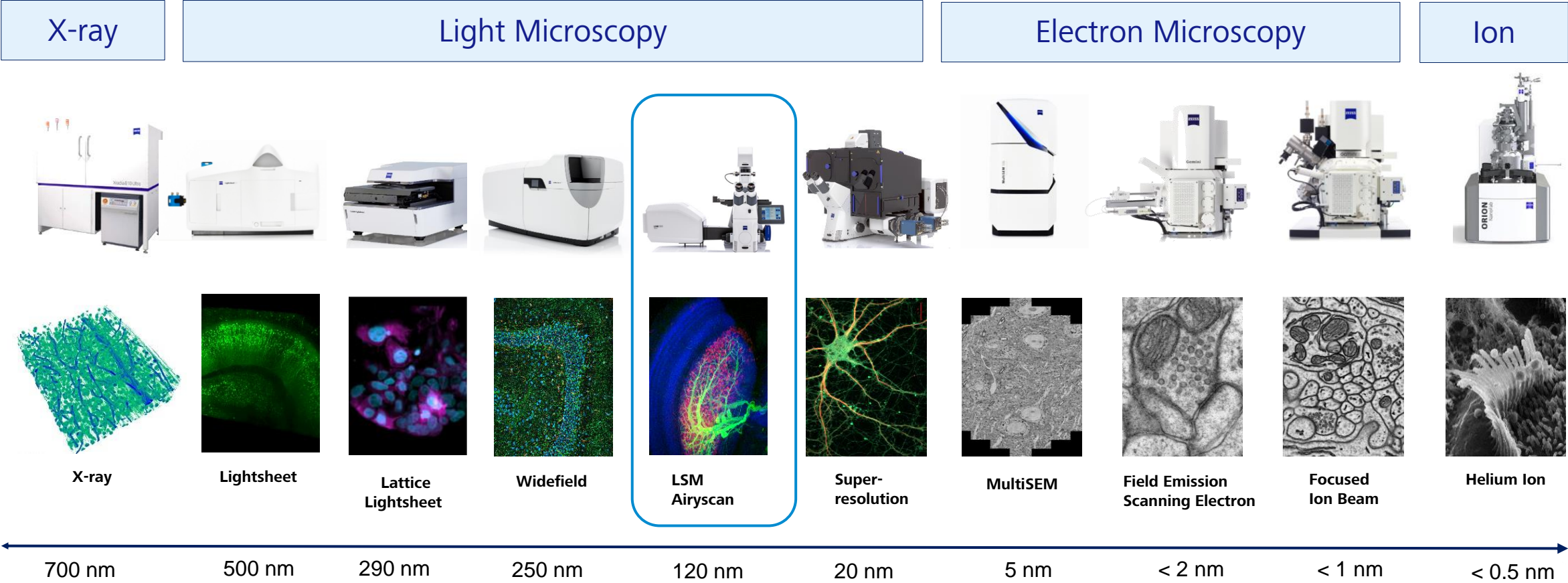

ZEISS LSM Confocal



Optical Sectioning | Extract the Layer of the Image

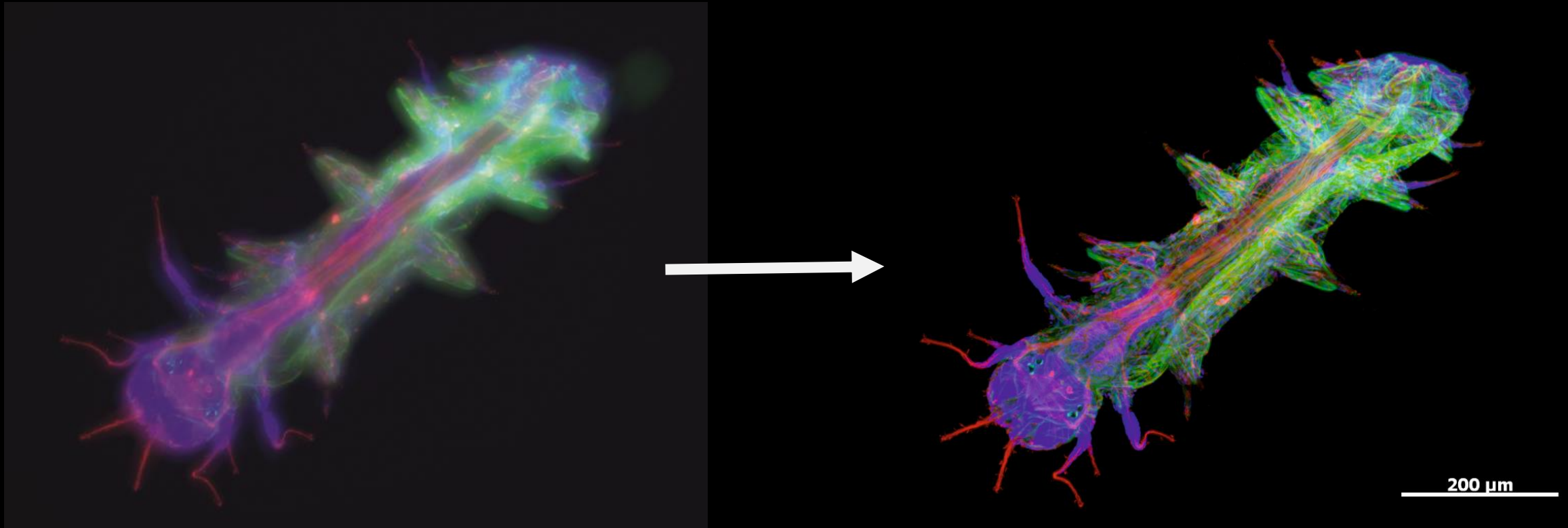

//

We want focused image!

//

Confocal microscopy allows you to optically section thick samples

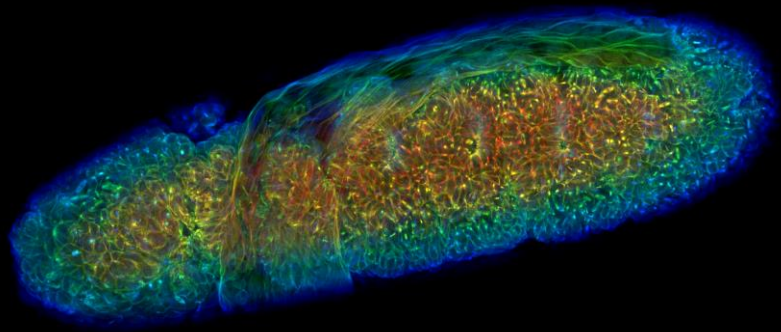
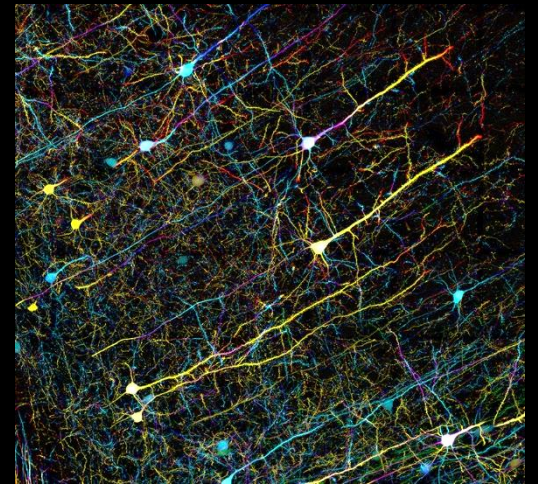
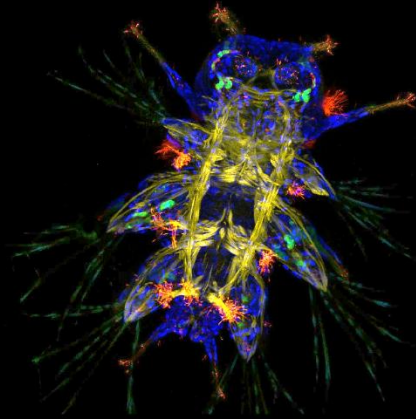
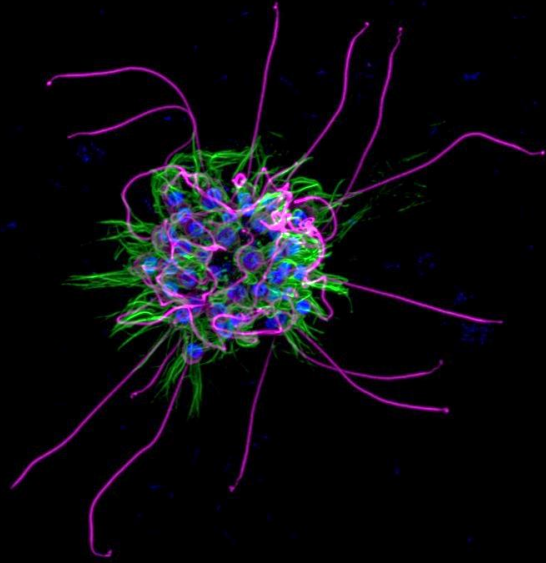

100 μm

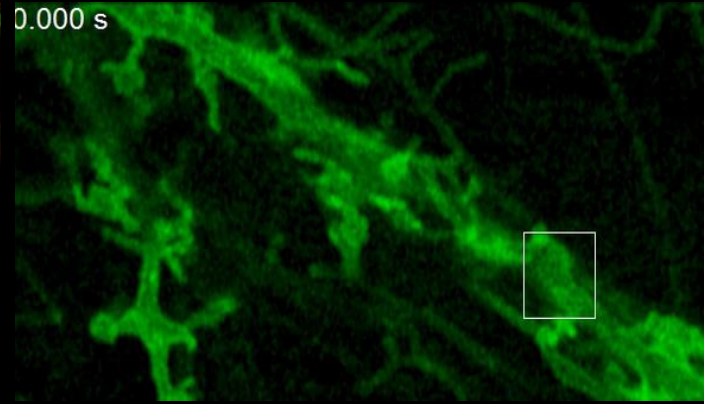
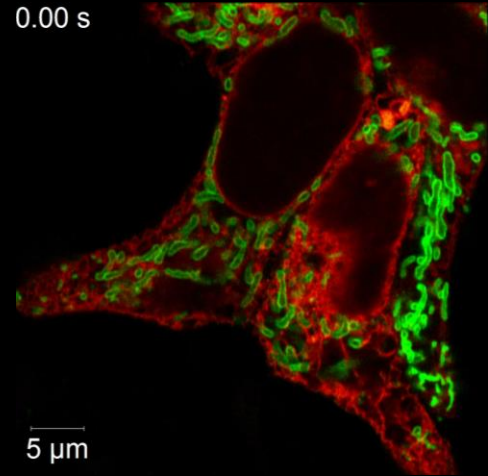
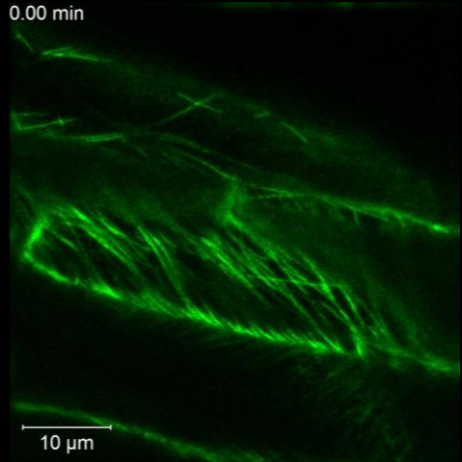

Holly Aaron (UC Berkeley); N. Kenny, K. McClelland, S. Miller (U of Oxford, U of Queensland, U of Cambridge), D. Reiff (U of Freiburg); Y. Zuo, A. Aharon, A. Schnulz (U of California Santa Cruz); Courtesy of Balazs Erdi, Max F. Perutz (Vienna Biocenter, Austria); Jason D Vevea (University of Wisconsin-Madison, USA); O. Samajova (Faculty of Science, Palacky University Olomouc, Poland)

LSM | Fast and Gentle Multiplex Imaging

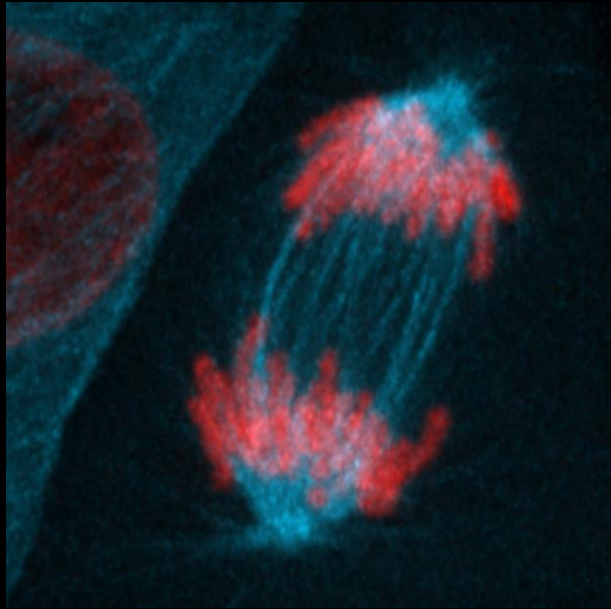

Highest sensitivity

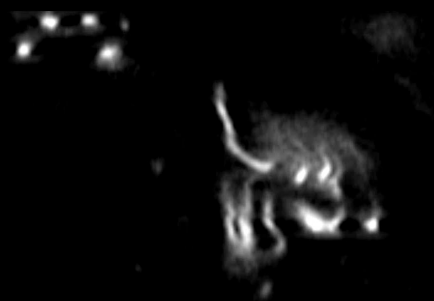

Fast &
High throughput

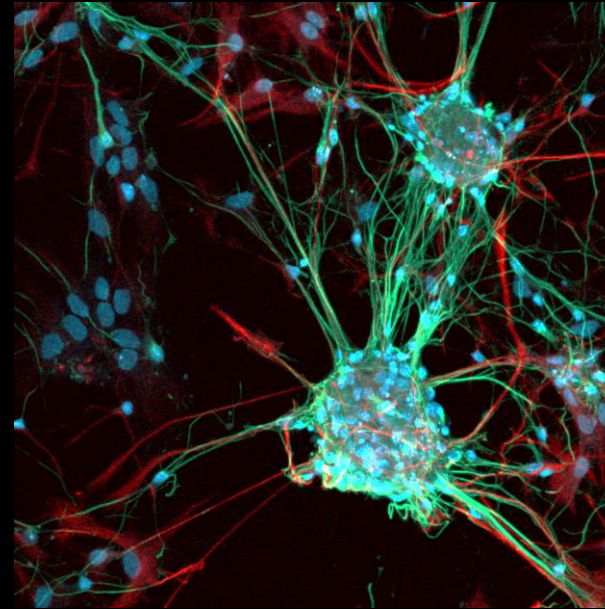

High resolution

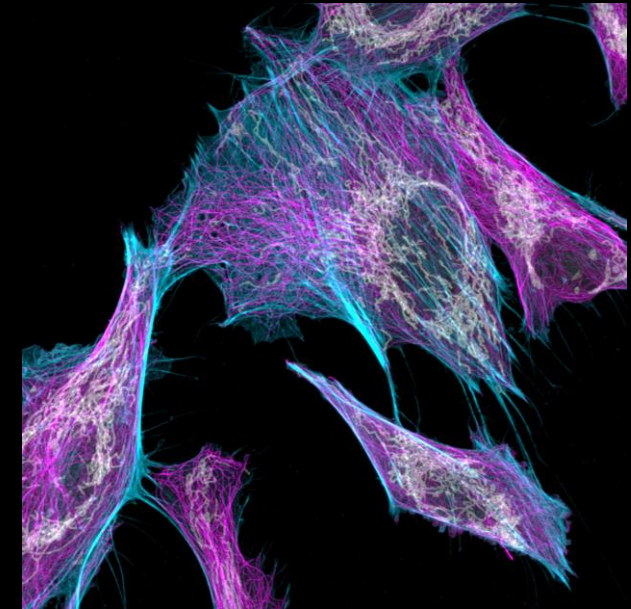

Spectral
multiplexing

LSM 9 Series | Versatile Confocal Platform

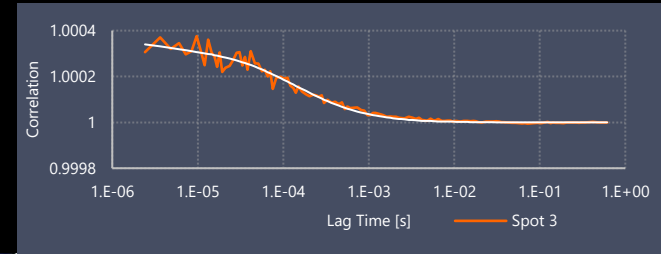

LSM Airyscan jDCV

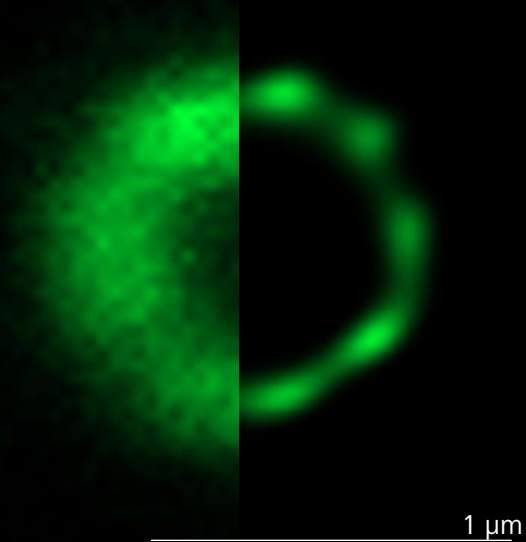

Airyscan 2

Superresolution

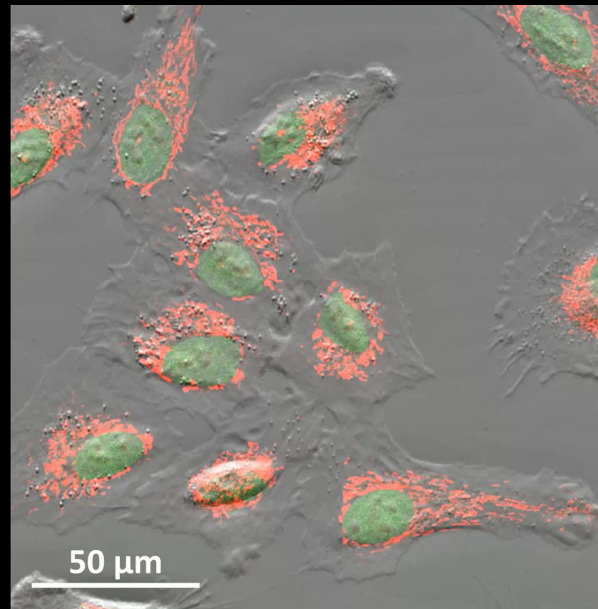

Incubation Module

Live cell imaging



AI Sample Finder

Automated imaging startup

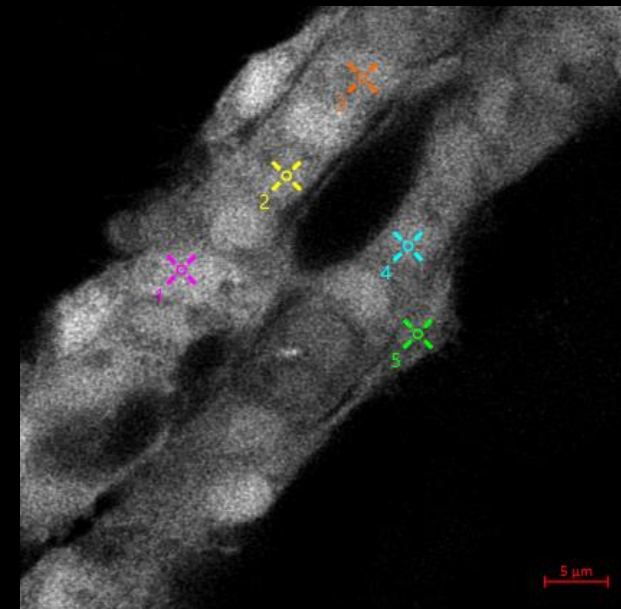

Dynamic Profiler

Gain molecular info

General Optical Sectioning Methods

Optical Sectioning Methods

Removing out-of focus light
(downstream strategy)

Blocking out-of focus light
(detection strategy)

Avoiding out-of focus light
(excitation strategy)

Deconvolution

Structured Illumination

Confocal Methods

Light sheet

Multi-Photon

Total Internal Reflection

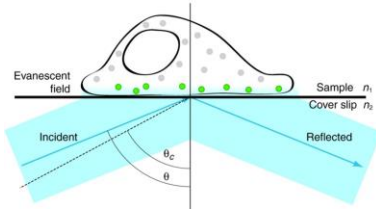
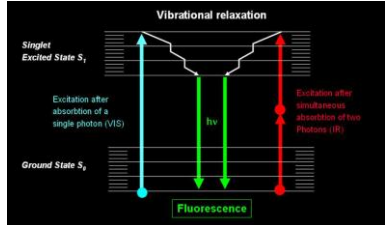
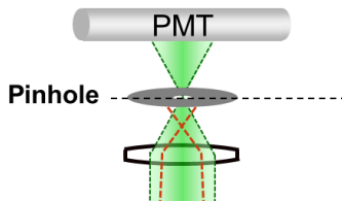
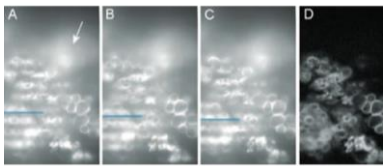
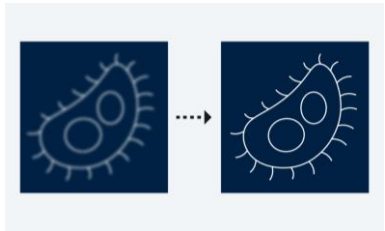

General Optical Sectioning Methods



Optical Sectioning Methods

Removing out-of focus light
(downstream strategy)

Blocking out-of focus light
(detection strategy)

Avoiding out-of focus light
(excitation strategy)

Deconvolution

Structured
Illumination

Confocal
Methods

Light sheet

Multi-Photon

Total Internal
Reflection

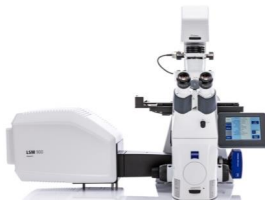

General Optical Sectioning Methods

Optical Sectioning Methods

Removing out-of focus light
(downstream strategy)

Blocking out-of focus light
(detection strategy)

Avoiding out-of focus light
(excitation strategy)

Deconvolution

Structured Illumination

Confocal Methods

Light sheet

Multi-Photon

Total Internal Reflection

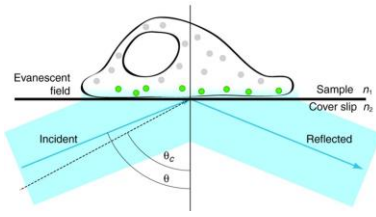
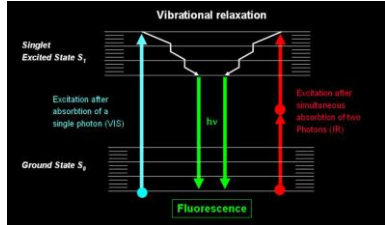
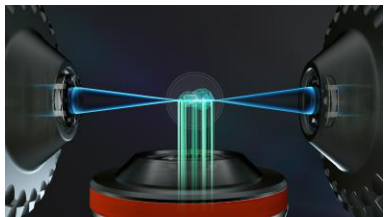
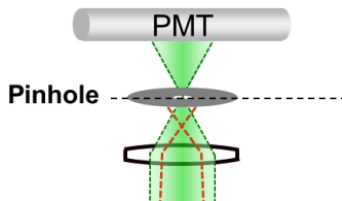
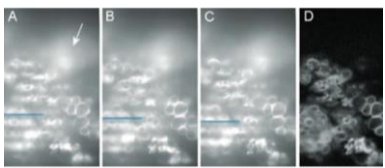
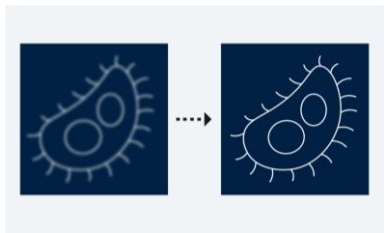

Noise-free Images are Physically Impossible

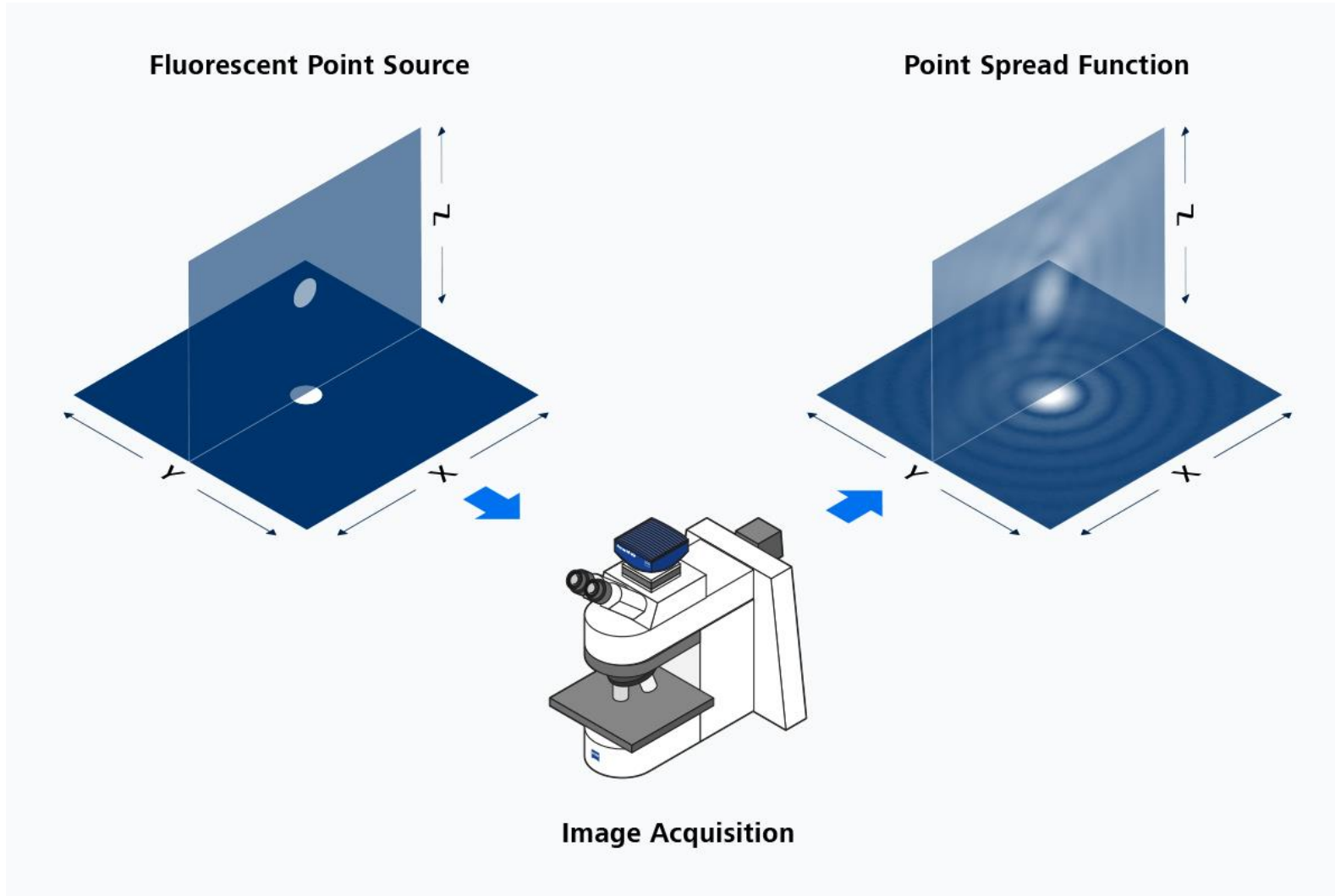

Point-Spread-Function

The image of a point is not a point. It's a complex 3-dimensional diffraction pattern.

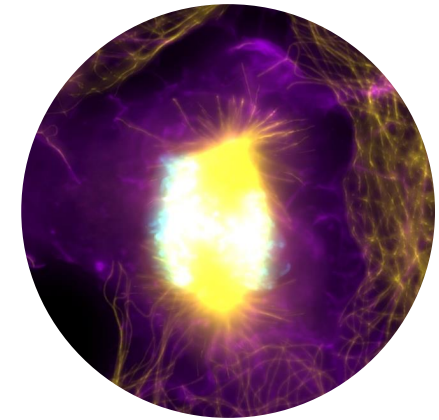
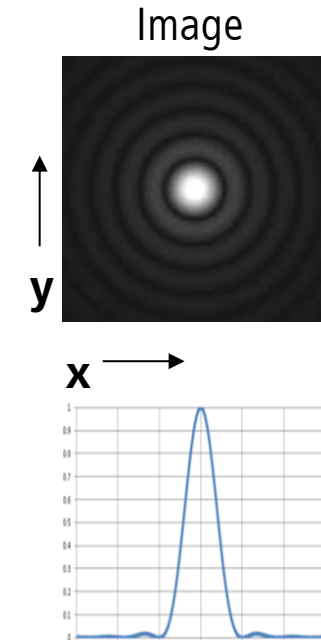

Imaging in Mathematical Terms

“Convolution” of the Object with the PSF

Sample

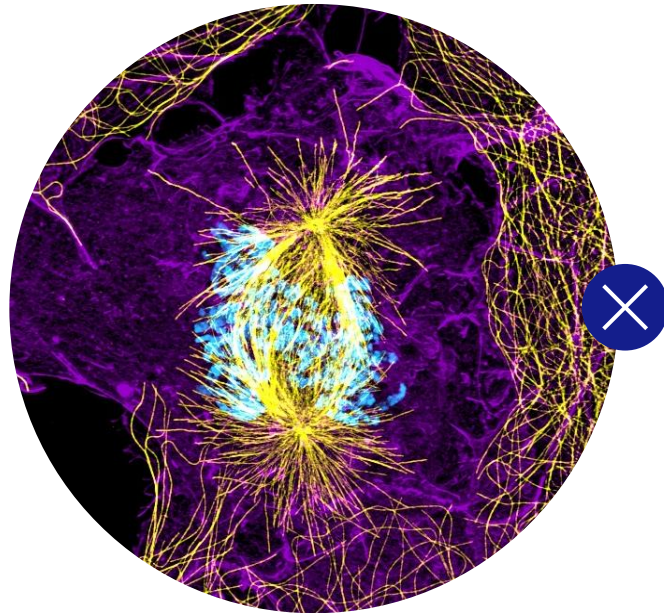

PSF

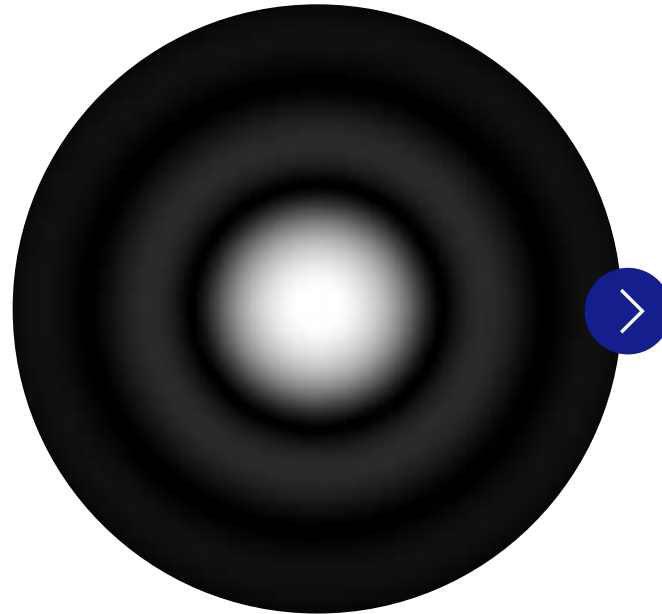

Image

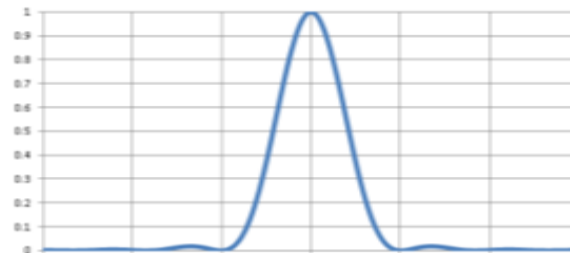
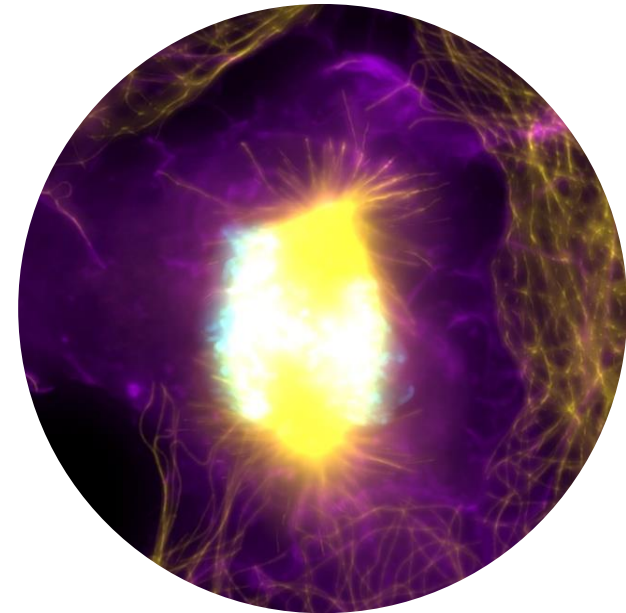

Inverting the Imaging-Process with Mathematics

A Deconvolution of the Image

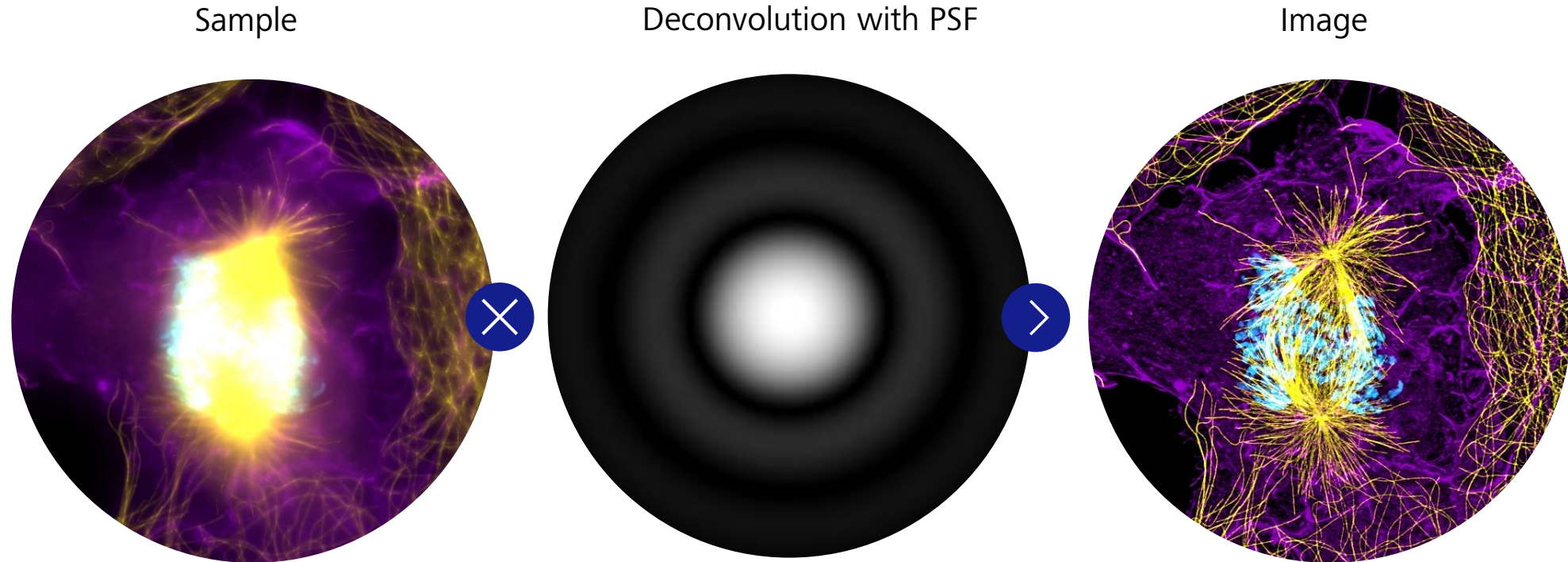

"Re-assignment" of "photons"

Widefield Imaging with Deconvolution

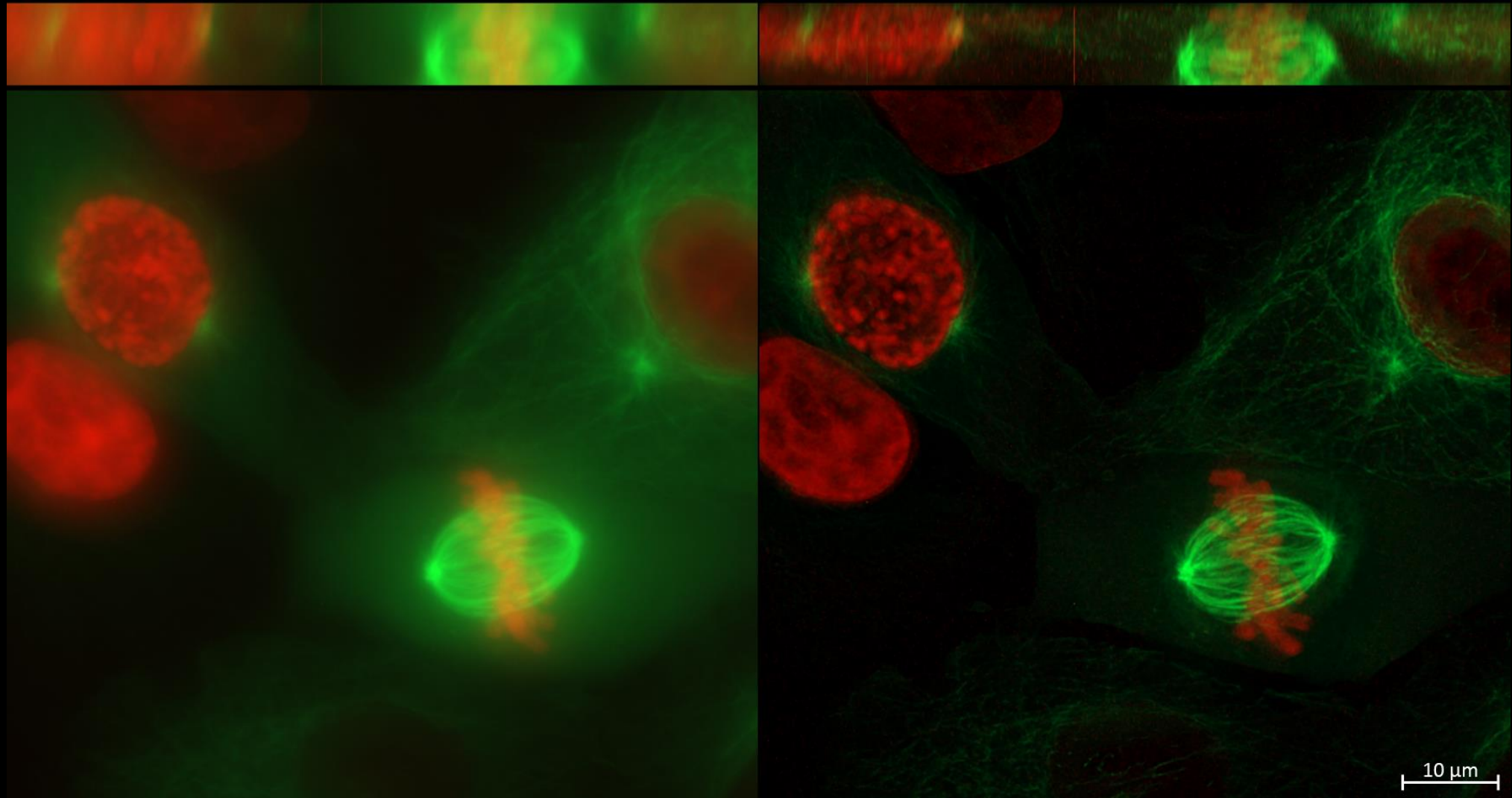

Deconvolution Algorithms



Raw

Deconvolution

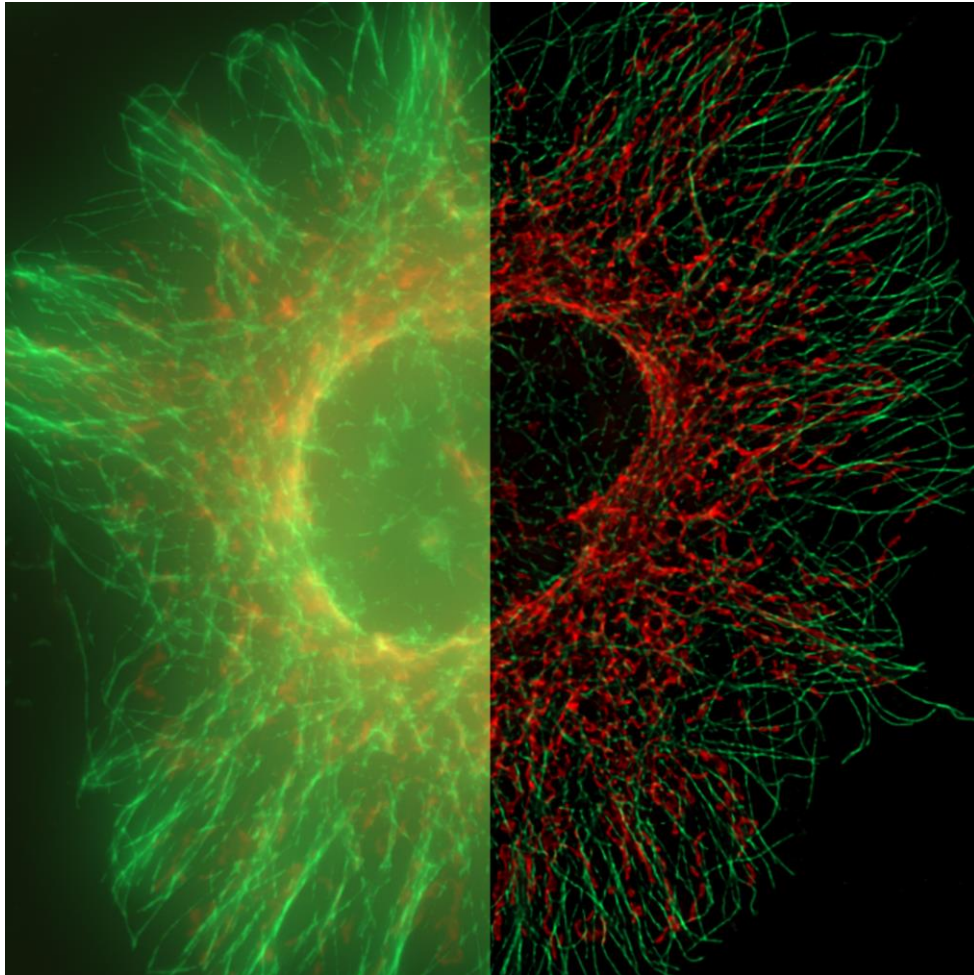

Fast

Slow



U2OS cells labeled for mitochondria (TOM20-mCherry) and microtubules (Tubulin-GFP) structures before and after Constrained Iterative Deconvolution.

A confocal microscopy image of Drosophila egg chambers. The image shows several overlapping, elongated, and somewhat conical structures. The structures are stained with two different fluorescent dyes: magenta and cyan. The magenta staining highlights the F-actin cytoskeleton, which appears as a dense, interconnected network of filaments. The cyan staining highlights DE-Cadherin, which appears as a more discrete, punctate pattern along the cell boundaries. The background is black, making the fluorescent structures stand out prominently.

A unique confocal experience

LSM Plus

Drosophila egg chambers stained for F-actin (Phalloidin,
magenta) and DE-Cadherin (cyan)

Sample courtesy of Thea Jacobs, AG Luschnig,
WWU Münster, together with
T. Zobel, Münster Imaging Network, Germany

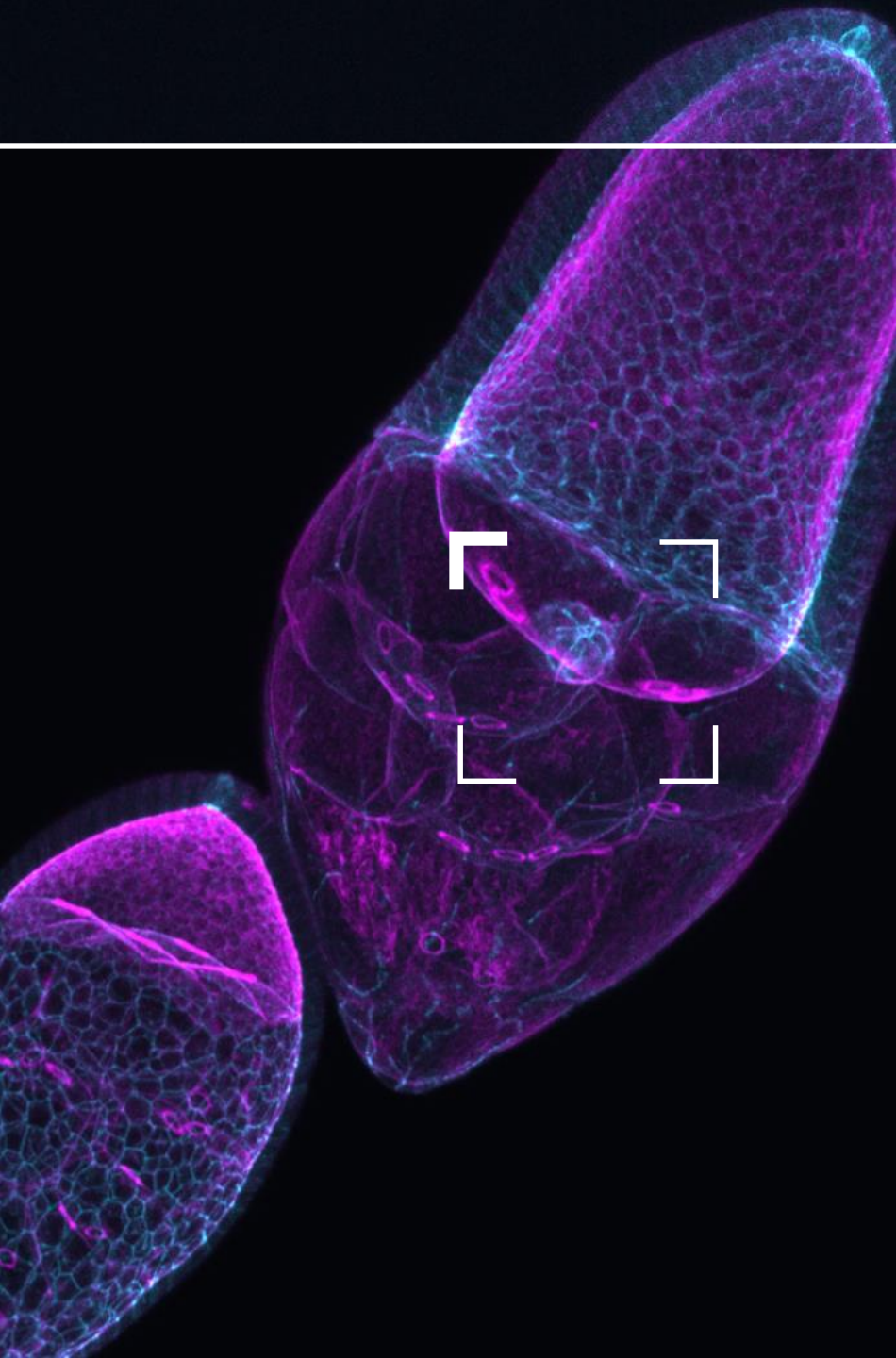
A confocal microscopy image of Drosophila egg chambers. The image shows several egg chambers, with the largest one in the center. The egg chambers are stained for F-actin (Phalloidin, magenta) and DE-Cadherin (cyan). The magenta staining highlights the actin filaments, while the cyan staining highlights the cell-cell junctions. White L-shaped brackets are overlaid on the image, indicating the regions of interest for the confocal experience.

A unique confocal experience

LSM Plus

Drosophila egg chambers stained for F-actin (Phalloidin,
magenta) and DE-Cadherin (cyan)

Sample courtesy of Thea Jacobs, AG Luschnig,
WWU Münster, together with
T. Zobel, Münster Imaging Network, Germany

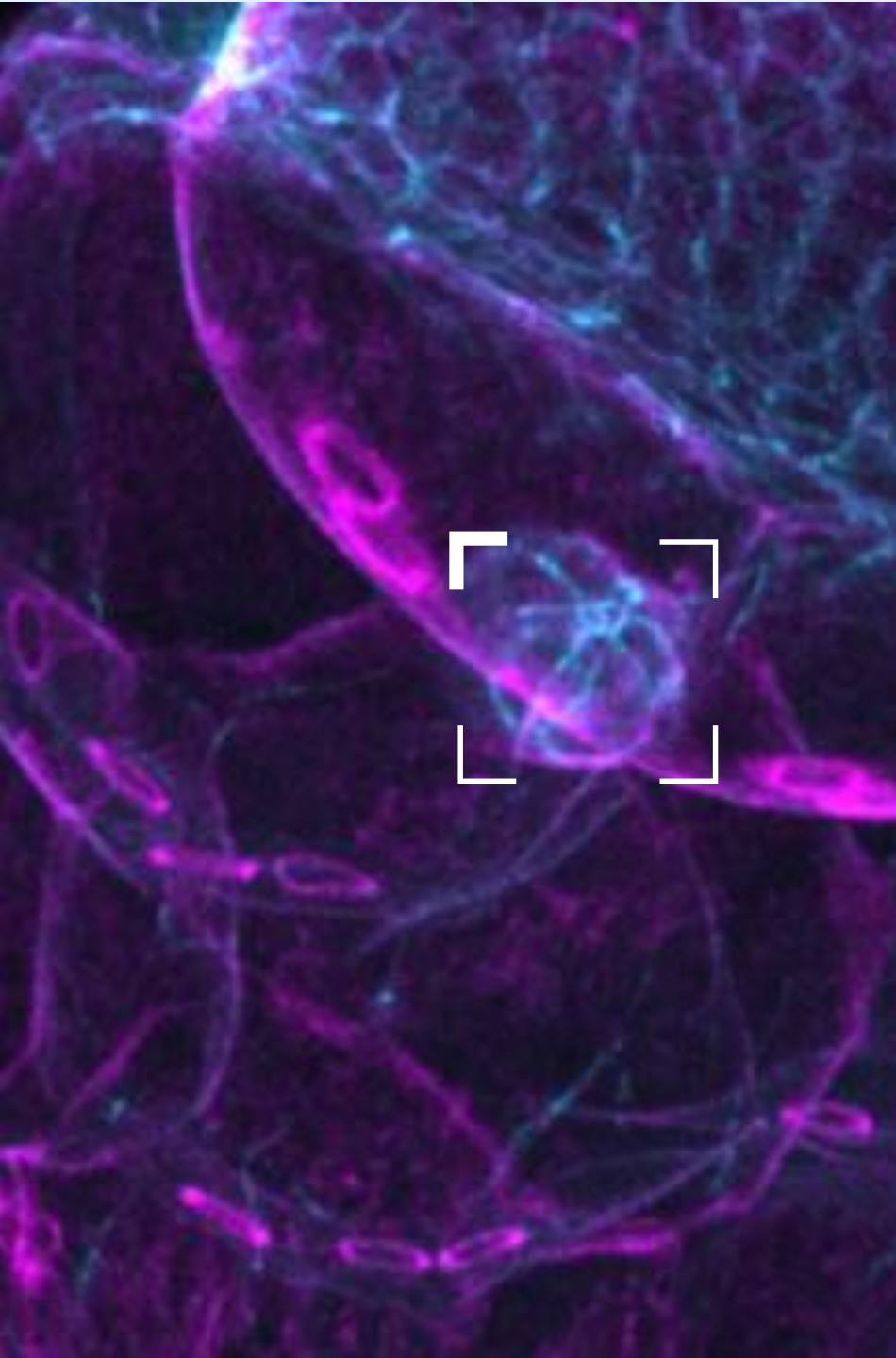

A unique confocal experience

LSM Plus

Drosophila egg chambers stained for F-actin (Phalloidin, magenta) and DE-Cadherin (cyan)

Sample courtesy of Thea Jacobs, AG Luschnig,
WWU Münster, together with
T. Zobel, Münster Imaging Network, Germany

LSM Plus: Better data, faster



LSM

LSM Plus

LSM 4x average

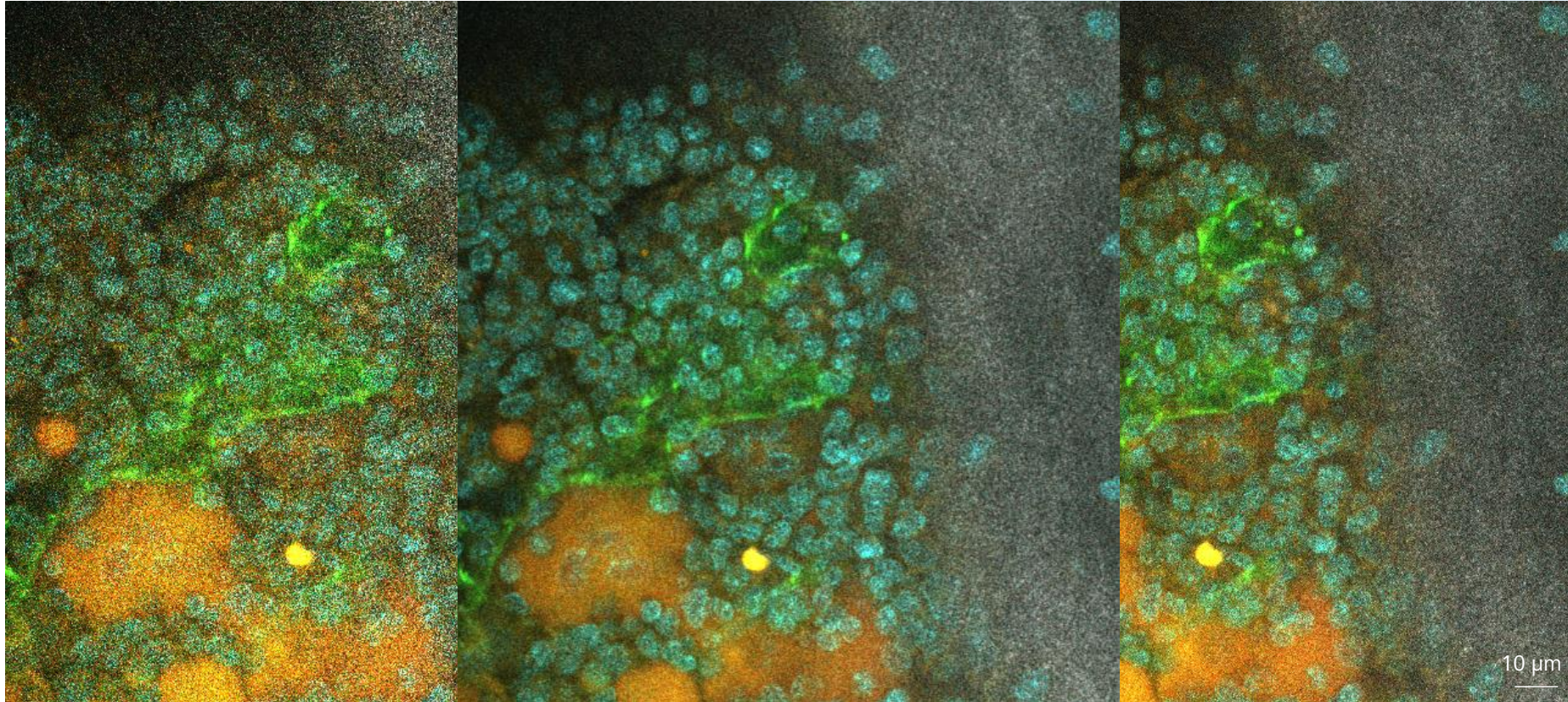
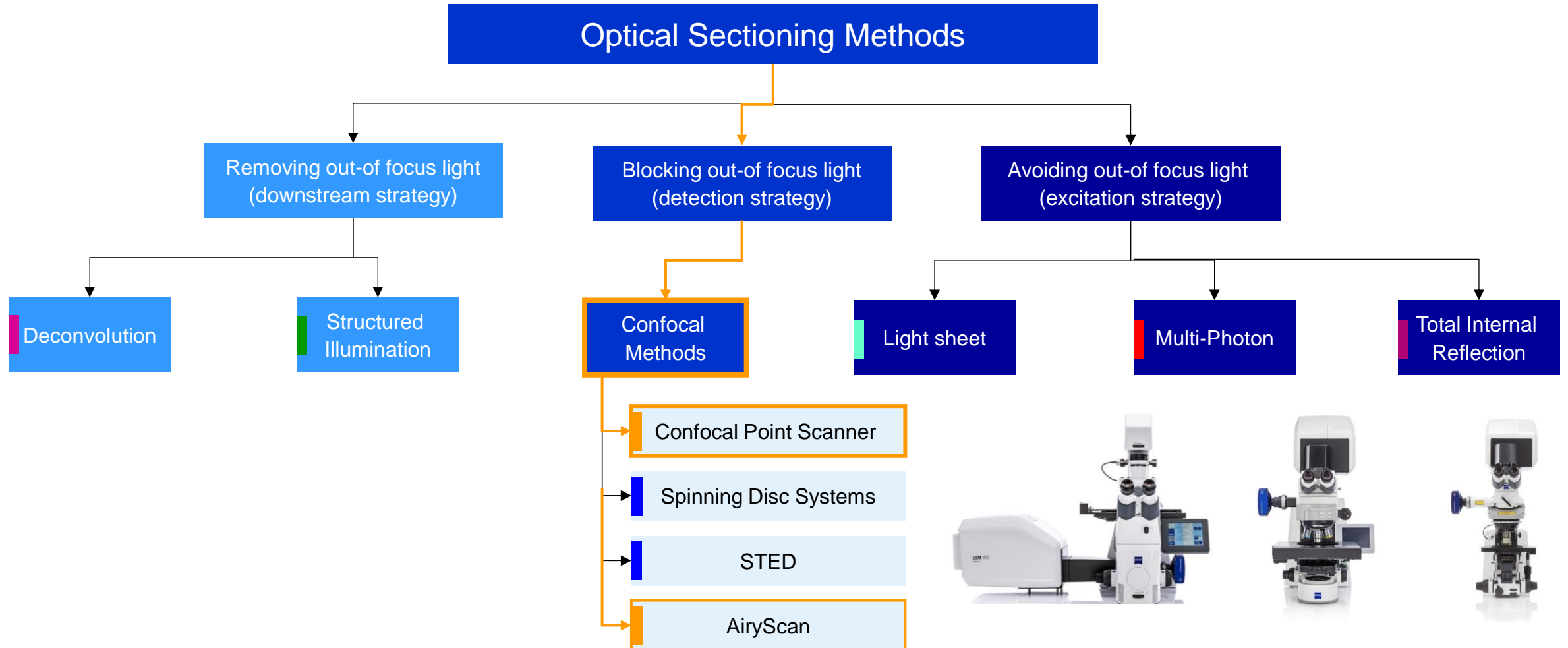

Image of bone marrow section showing bone (grey), endomucin vessels (green), dapi (blue) and megakaryocytes (red). Courtesy of George Adams (Imperial College London).

General Optical Sectioning Methods





Why do we need optical sectioning



We want focused image



Unfocused images are annoying



The Point-spread-function of a Microscope

Point-Spread-Function

The image of a point is not a point.

fluorescent point source

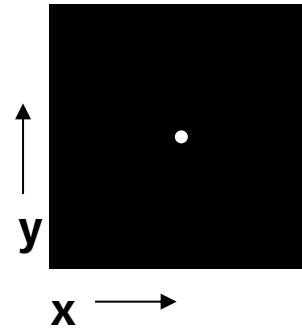

The Point-spread-function of a Microscope

Point-Spread-Function

The image of a point is not a point.

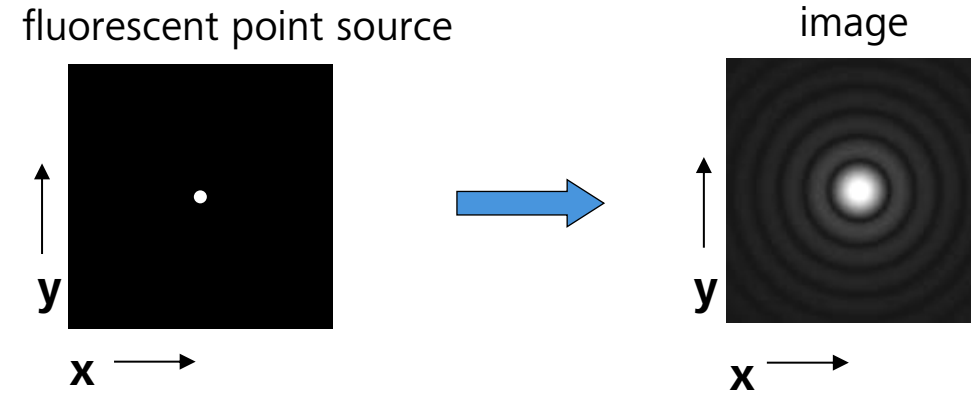

General Optical Sectioning Methods

Point-Spread-Function

The image of a point is not a point.

It's a complex 3D diffraction pattern.

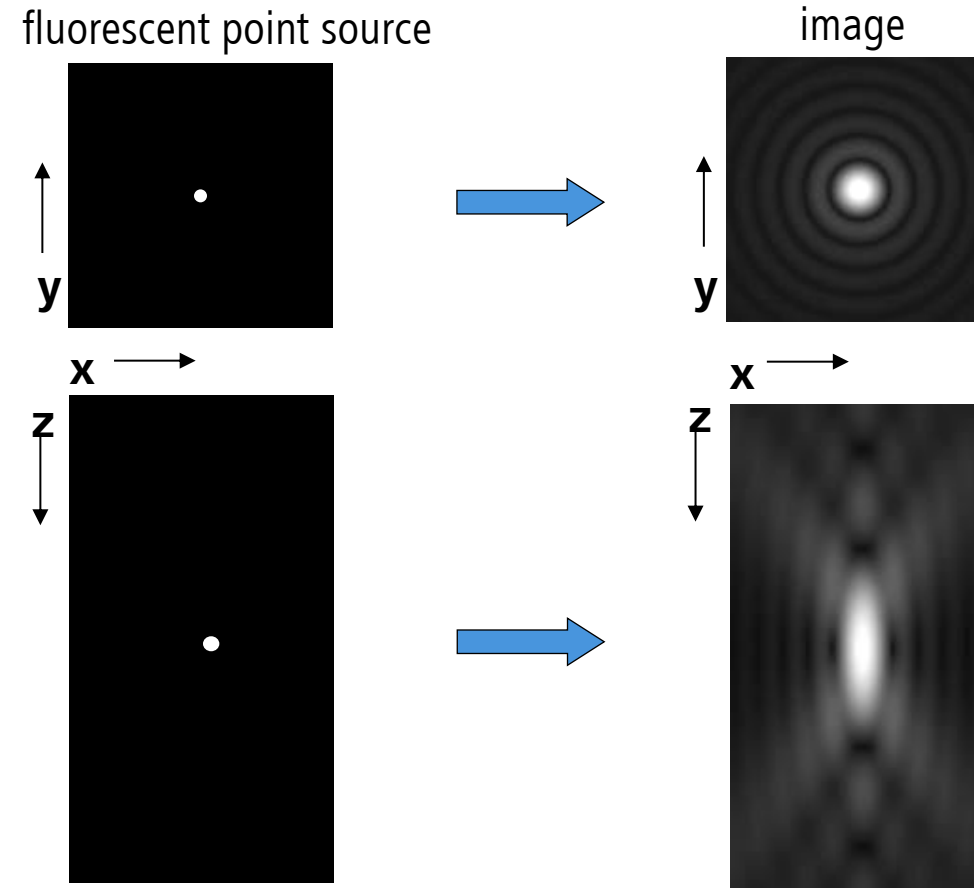

General Optical Sectioning Methods

Point-Spread-Function

The image of a point is not a point.

It's a complex 3D diffraction pattern.

Dimensions of the central peak:

$$r_{lateral} \approx 0,6 \frac{\lambda}{NA}$$

$$r_{axial} \approx 2 \frac{n \cdot \lambda}{NA^2}$$

fluorescent point source

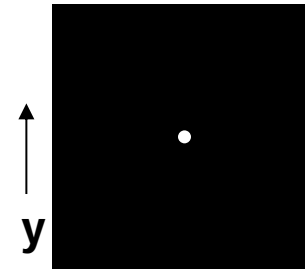

image

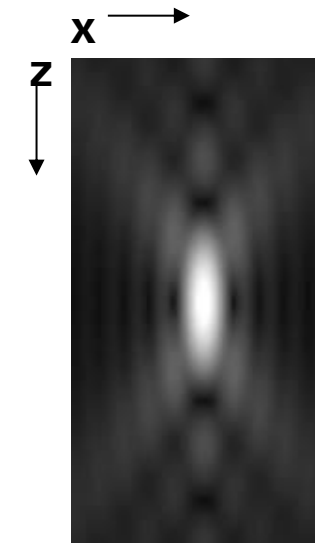
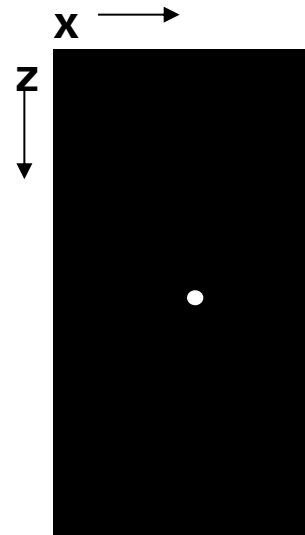
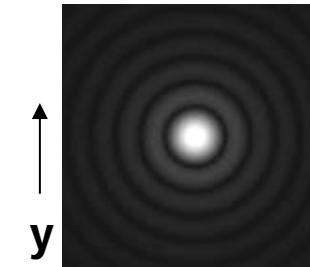

Defocusing of an Object

Conventional microscope

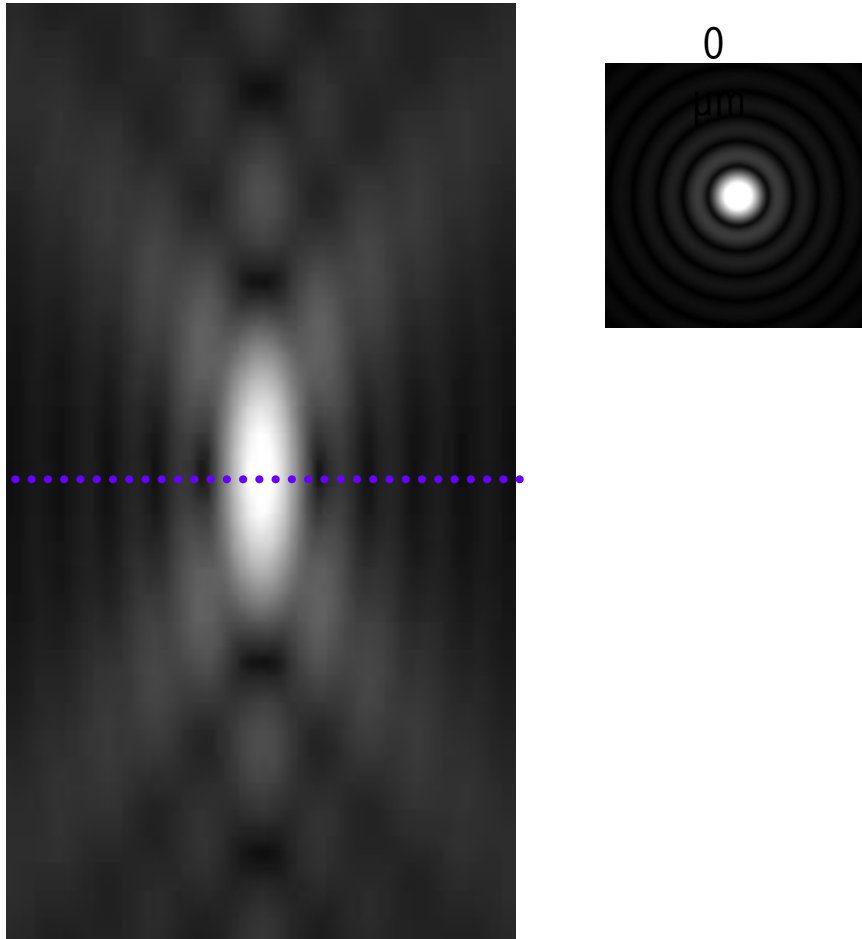

Defocusing of an Object

Conventional microscope

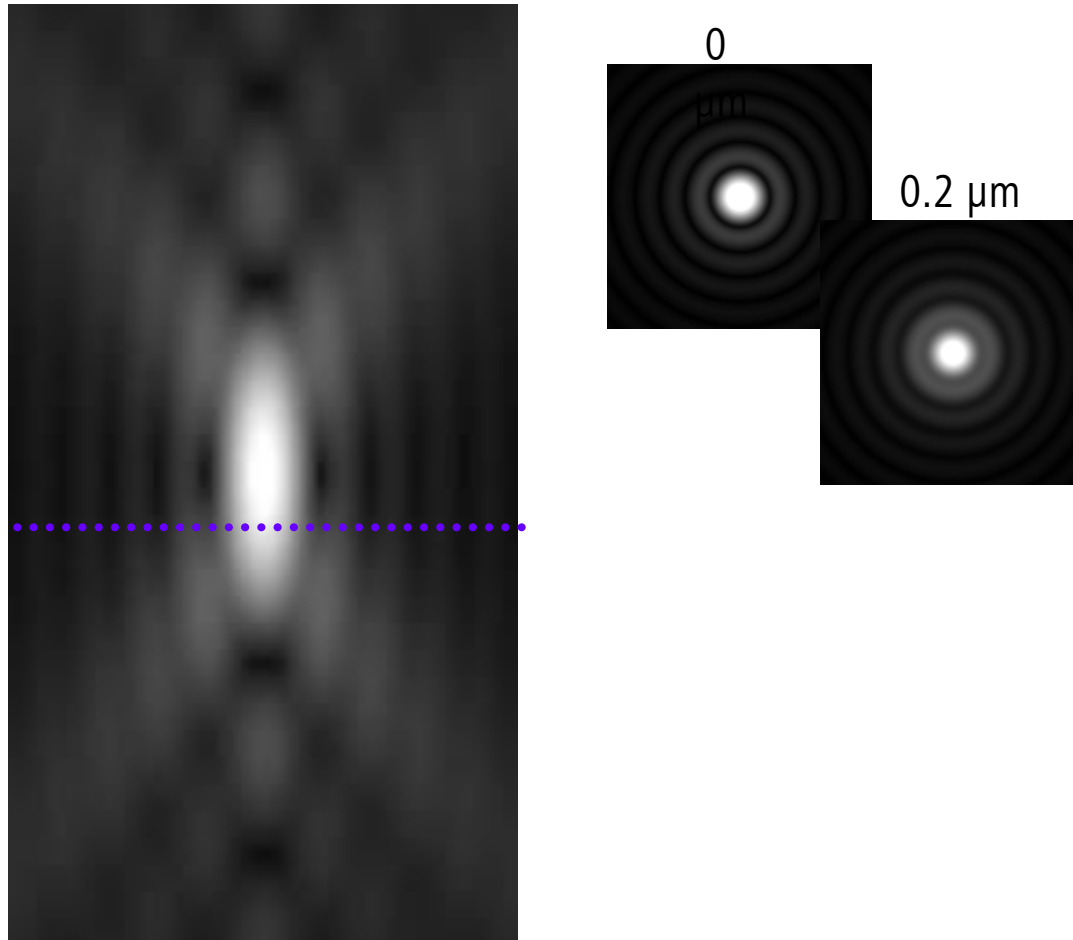

Defocusing of an Object

Conventional microscope

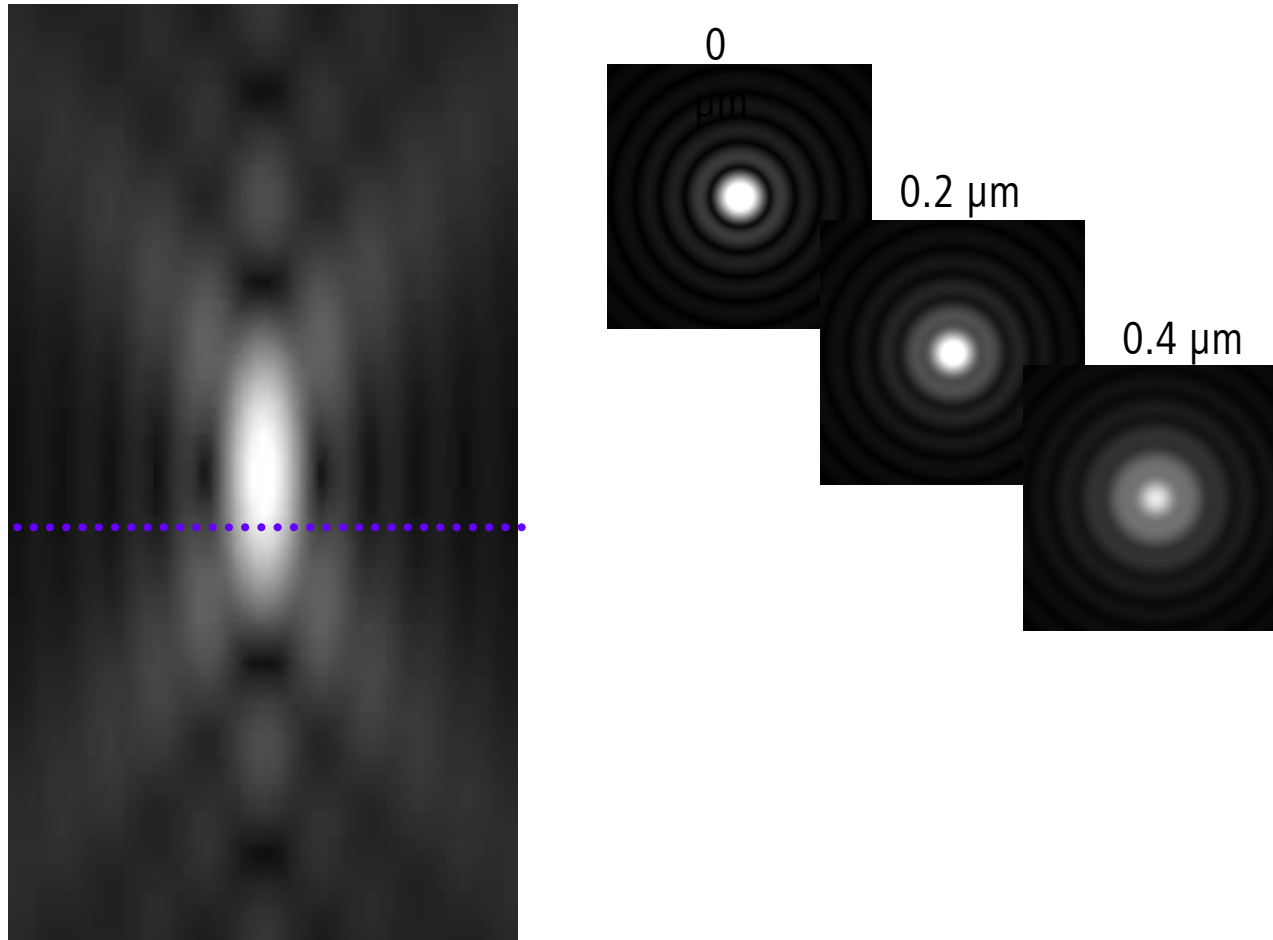

Defocusing of an Object

Conventional microscope

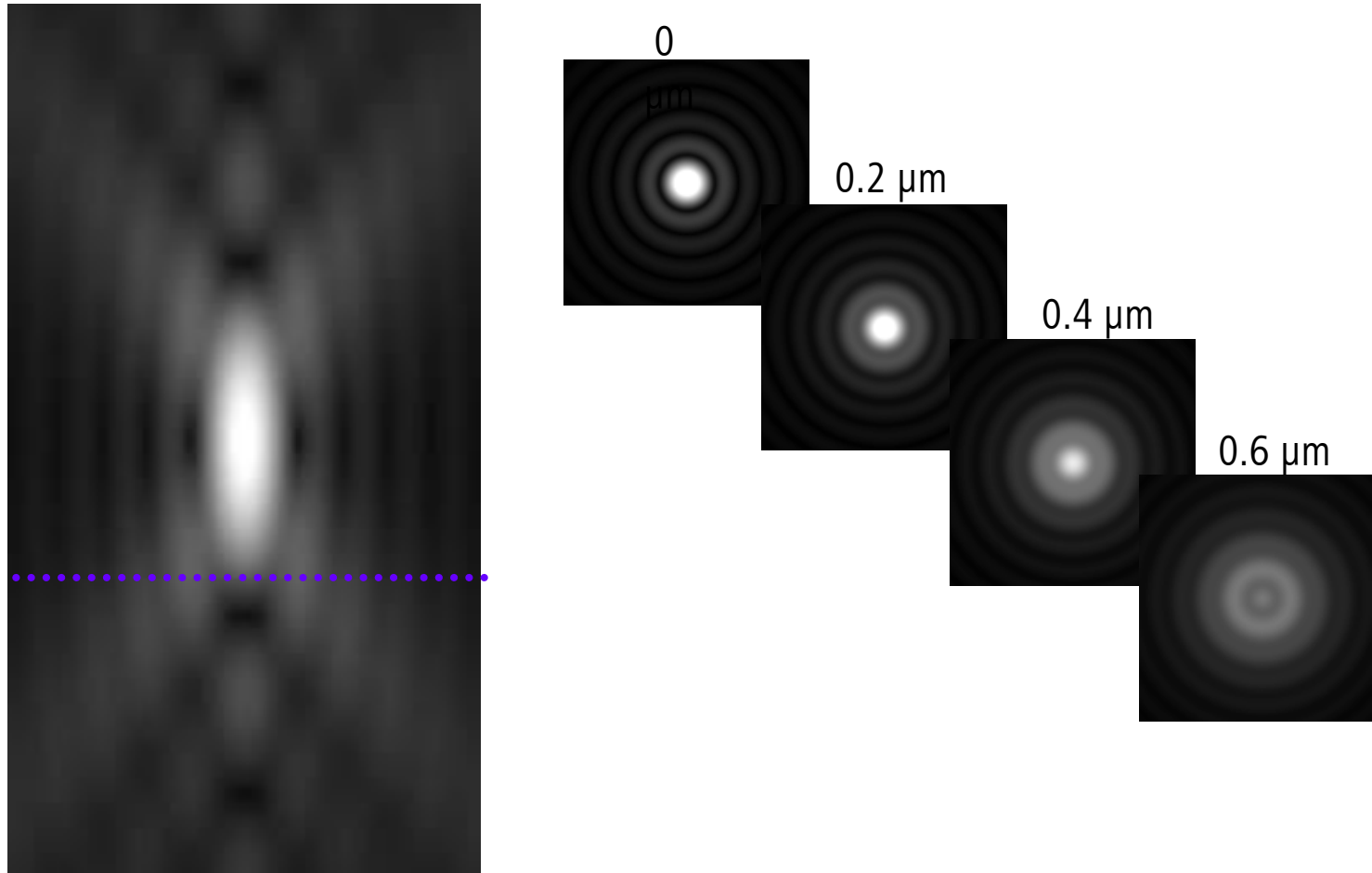

Defocusing of an Object

Conventional microscope

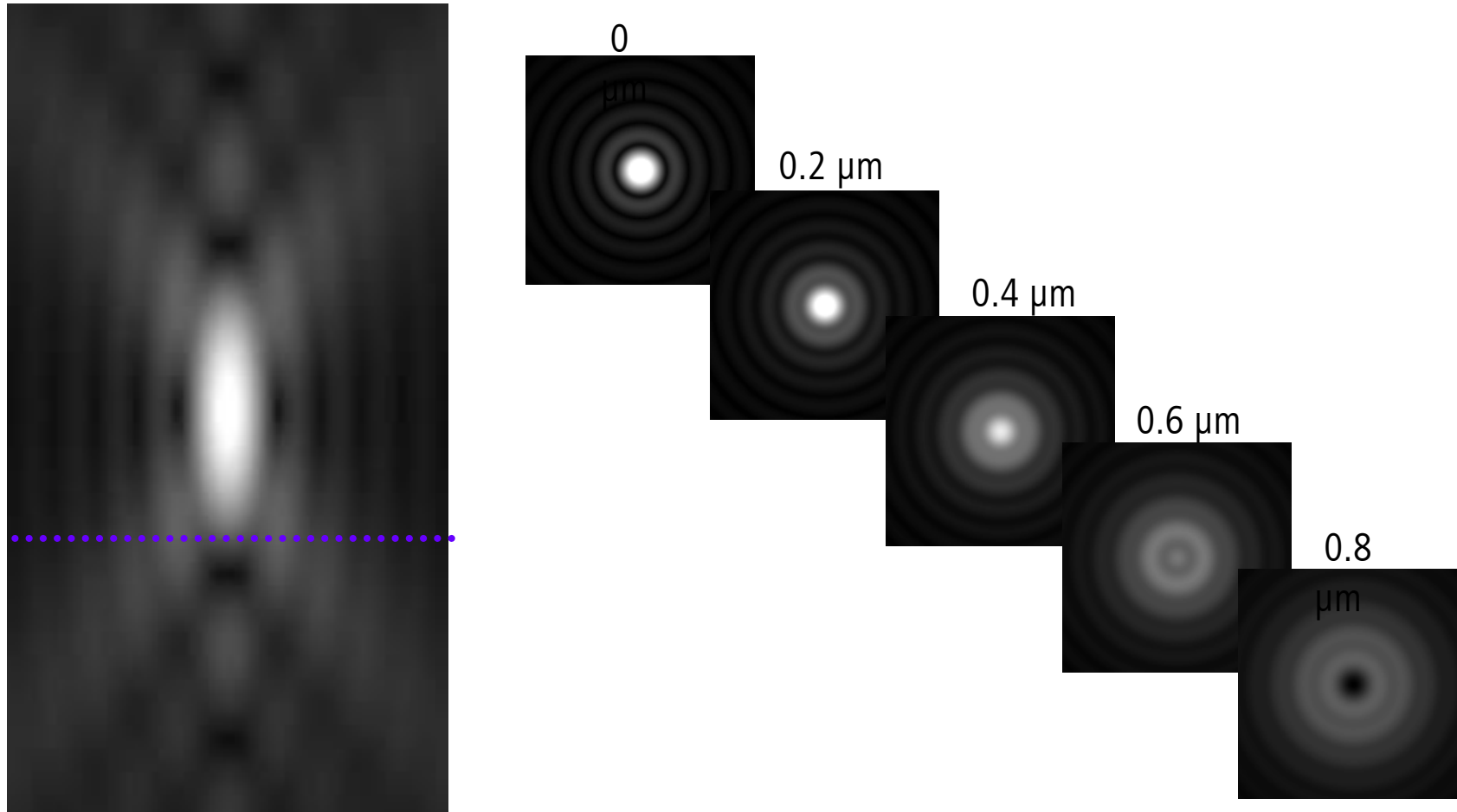

Defocusing of an object

Conventional microscope

The integrated intensity in each image is independent of the distance from the focal plane!

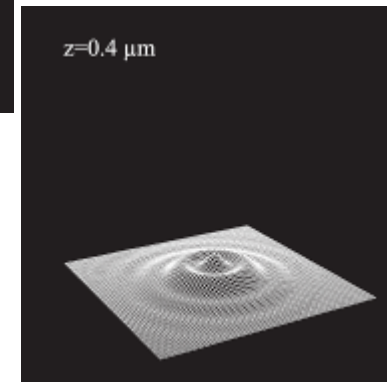
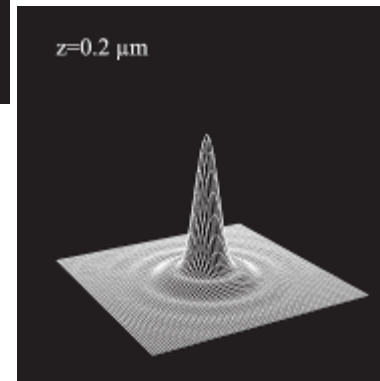
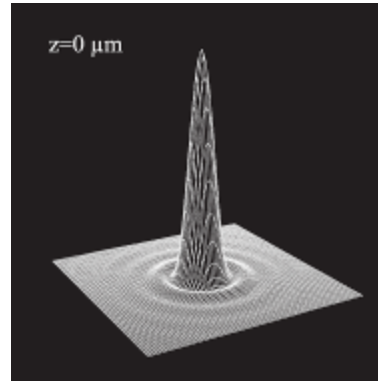
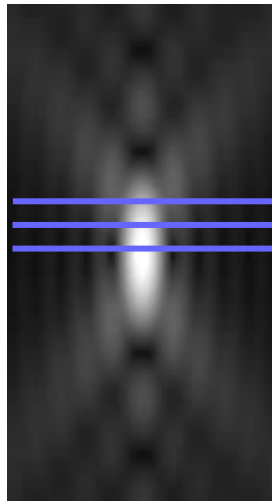

What is an optical section?

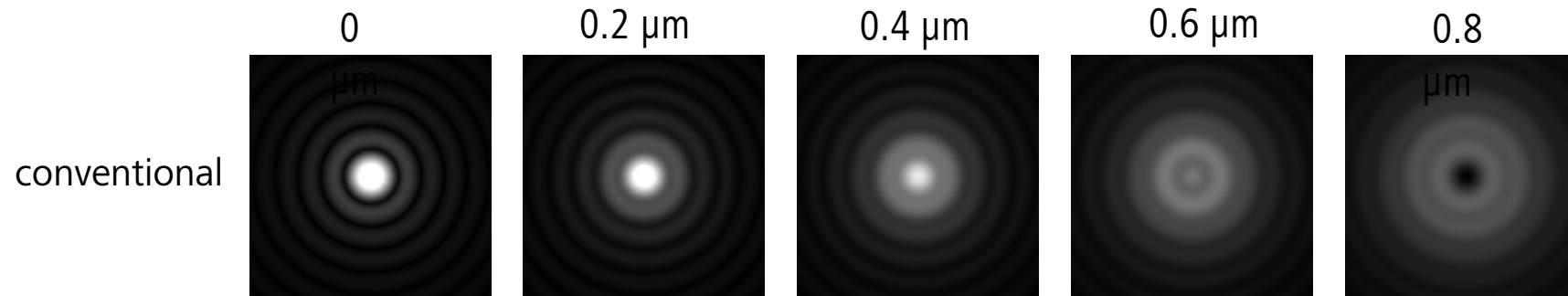

The integrated intensity in each image plane is **independent** of the axial position!

What is an optical section?

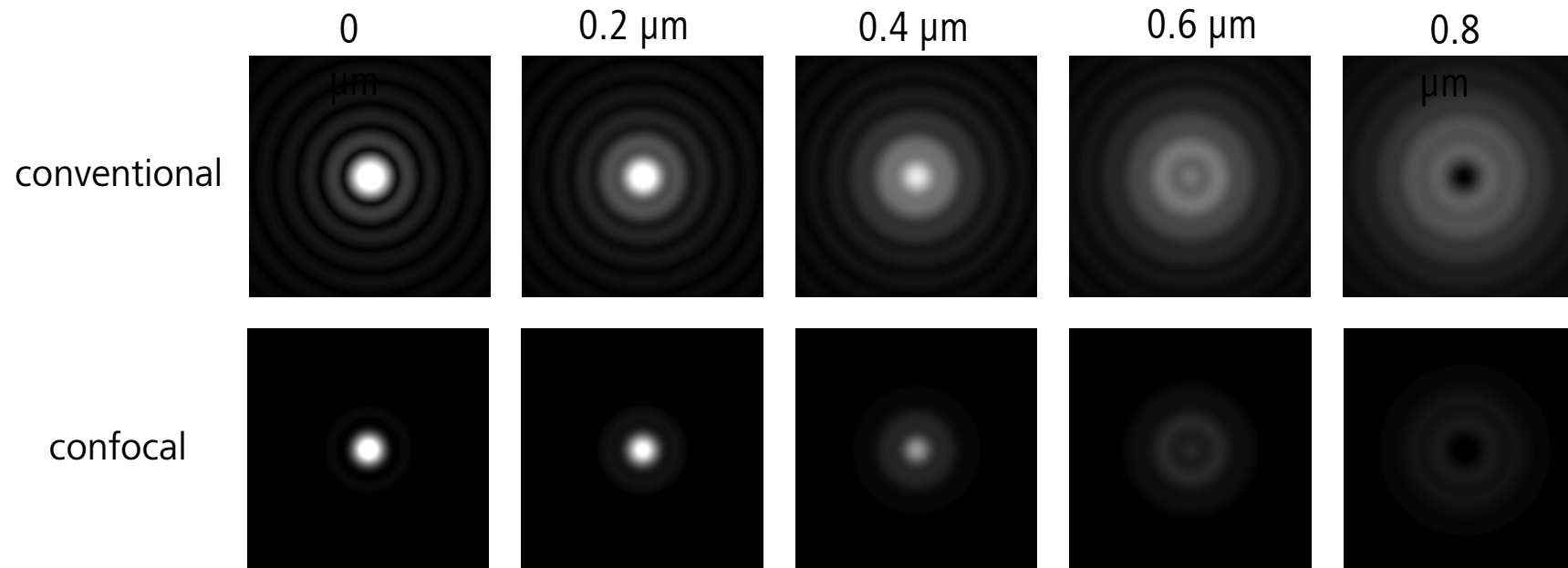

The integrated intensity in each image plane is **independent** of the axial position!

ZEISS LSM Confocal

Inverted microscope



Software



Scanning module



ZEISS LSM Confocal

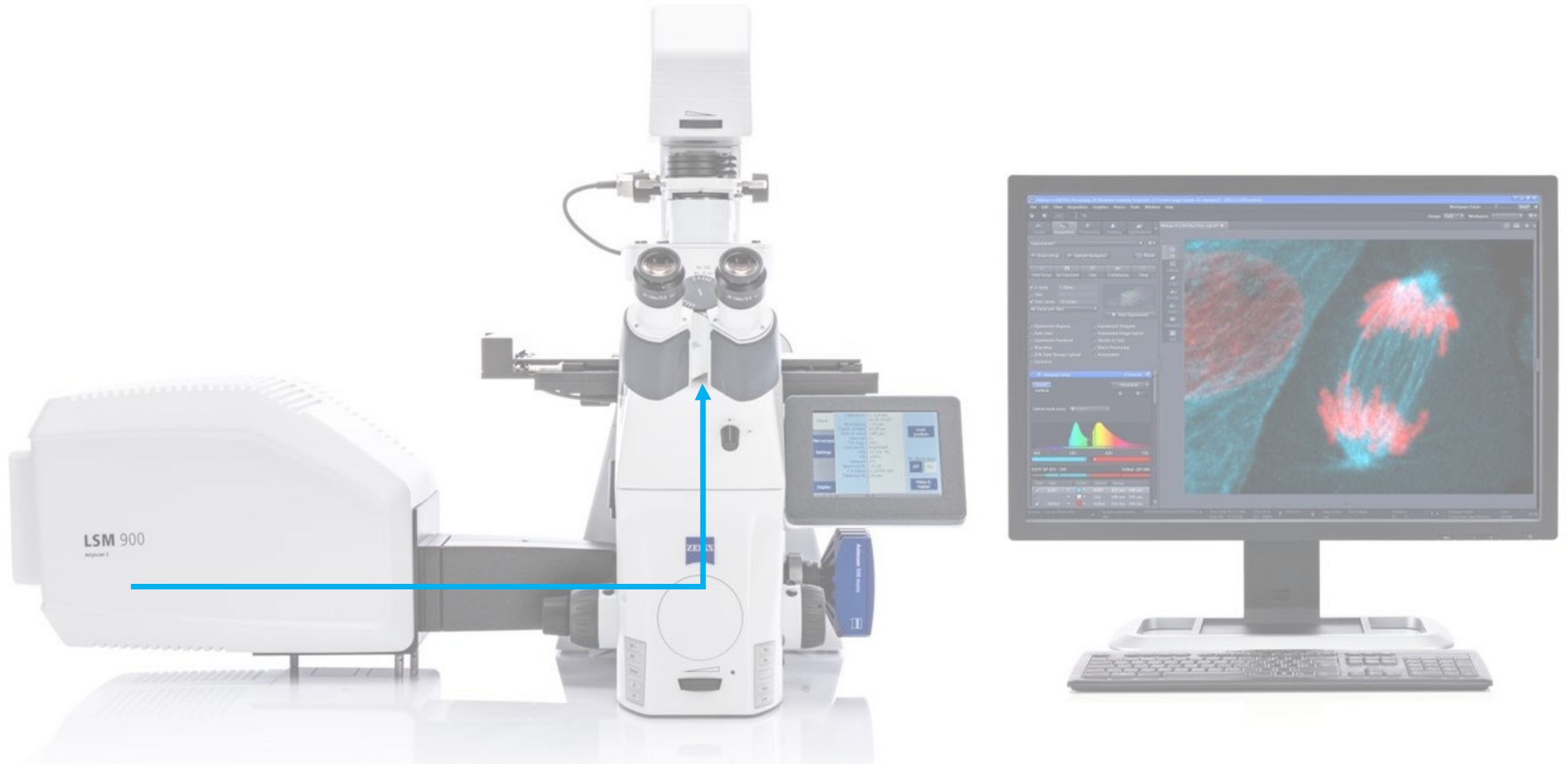

ZEISS LSM Confocal

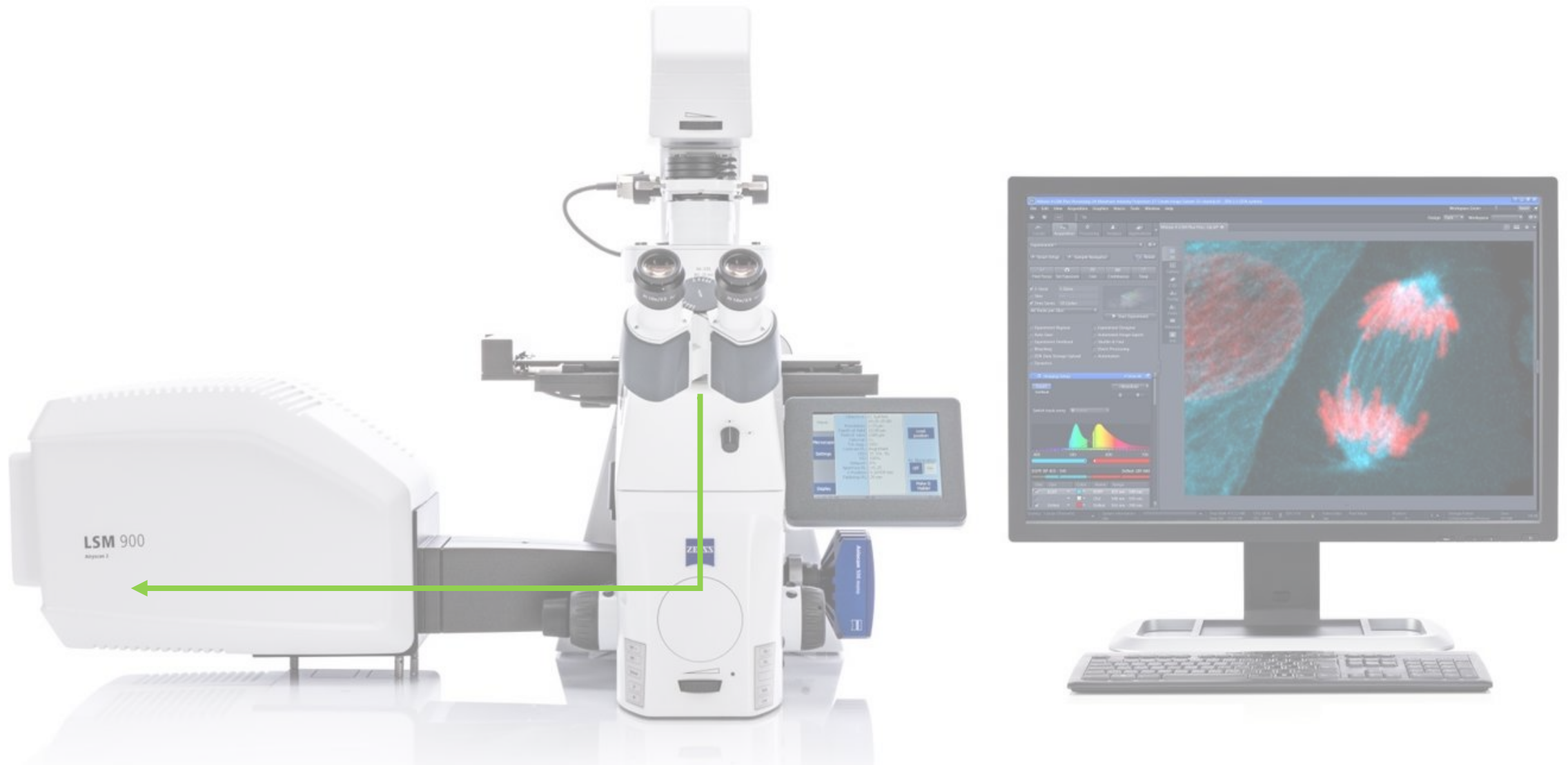

Point Scanning Confocal Microscopes

Confocal principle

Spot Illumination

A laser beam which is focussed to a diffraction limited spot illuminates the sample and is used for fluorescence excitation.

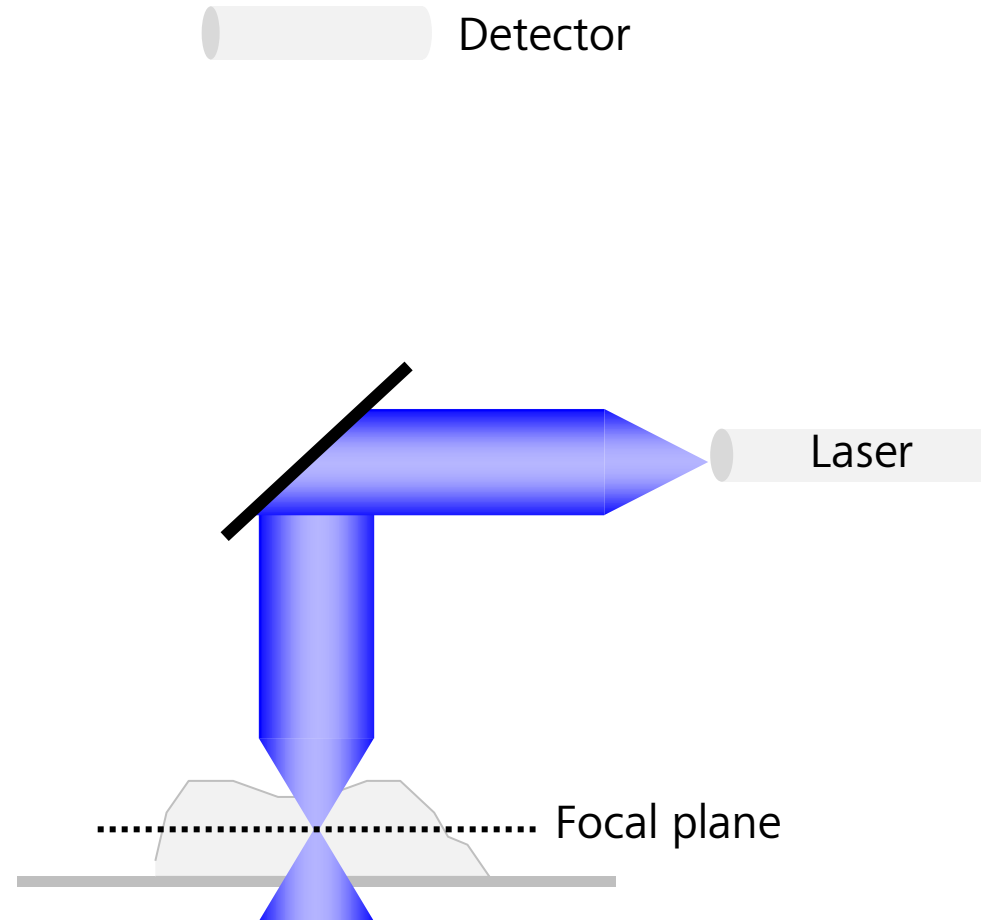

Point Scanning Confocal Microscopes

Confocal principle

Spot detection

The emitted fluorescence light is separated from the excitation light by appropriate beamsplitters and is usually detected by a photomultiplier.

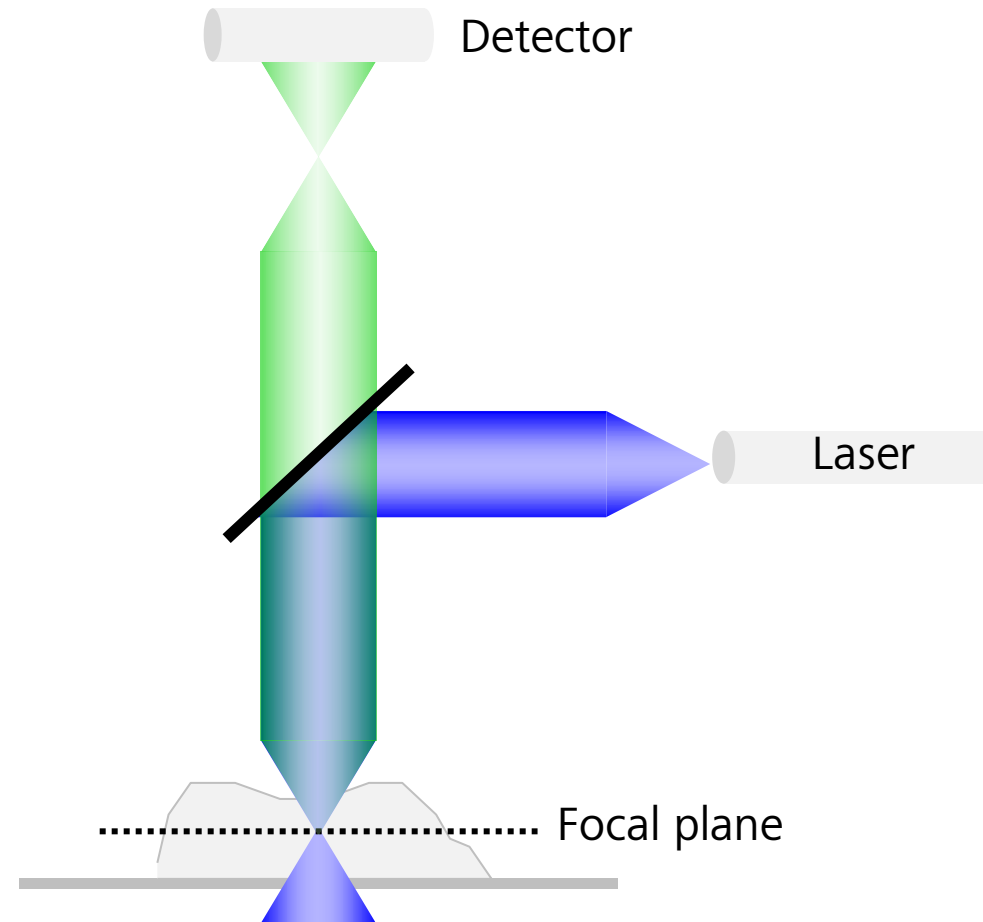

Point Scanning Confocal Microscopes

Confocal principle

Spot detection

The emitted fluorescence light is separated from the excitation light by appropriate beamsplitters and is usually detected by a photomultiplier.

The crucial part is the pinhole, which is placed in front of the detector – in a conjugated plane to the focal plane of the objective.

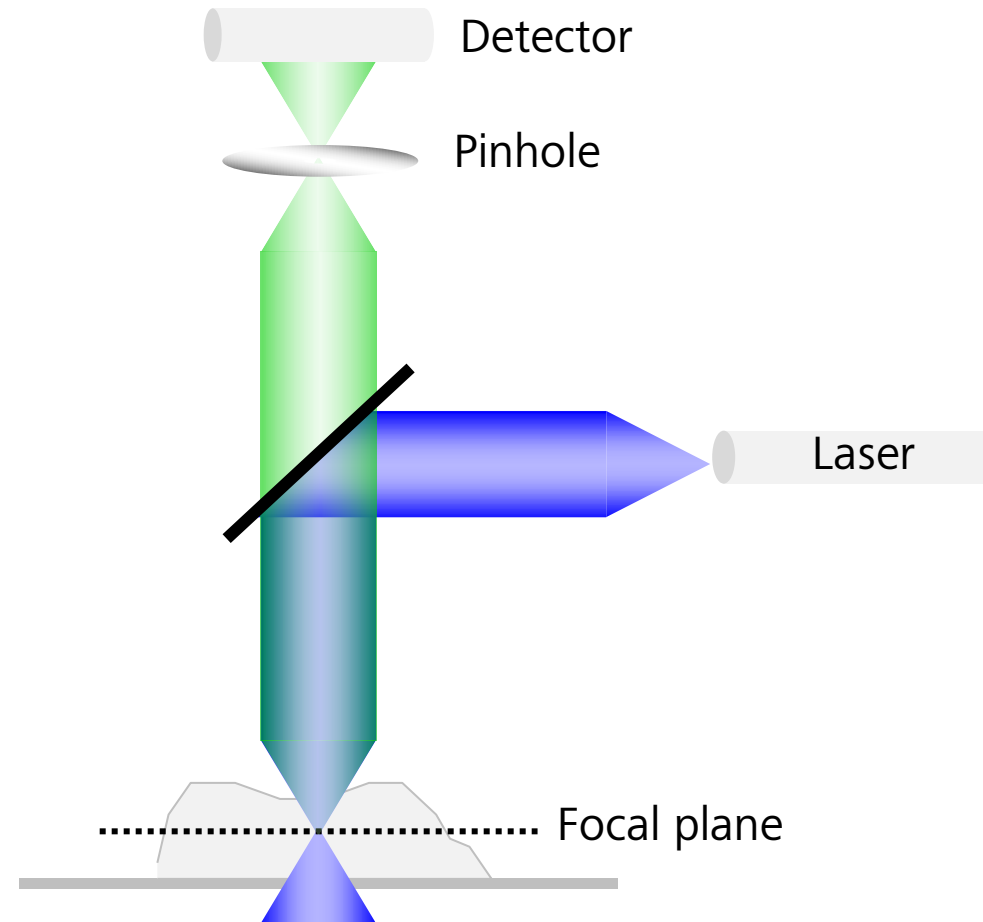

Point Scanning Confocal Microscopes

Confocal principle

Spot detection

This pinhole simply blocks fluorescence light, which originates from above or below the focal plane of the objective.

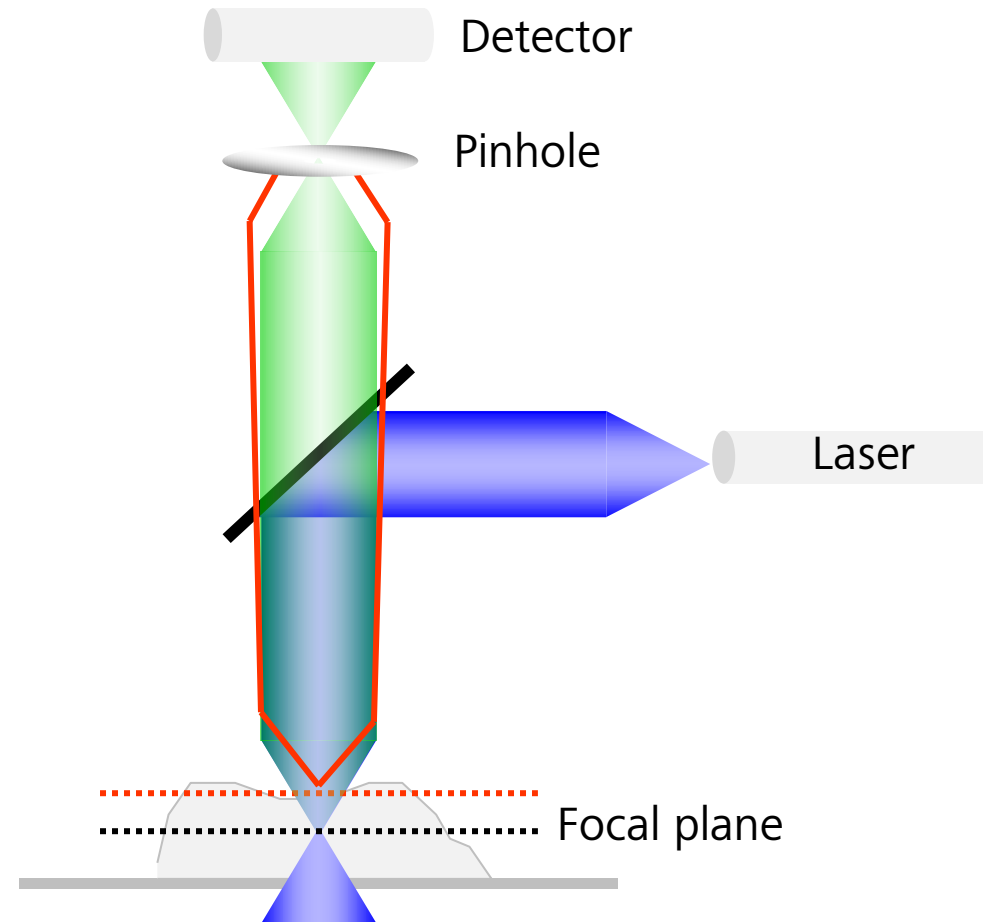

Point Scanning Confocal Microscopes

Confocal principle

Spot detection

This pinhole simply blocks fluorescence light, which originates from above or below the focal plane of the objective.

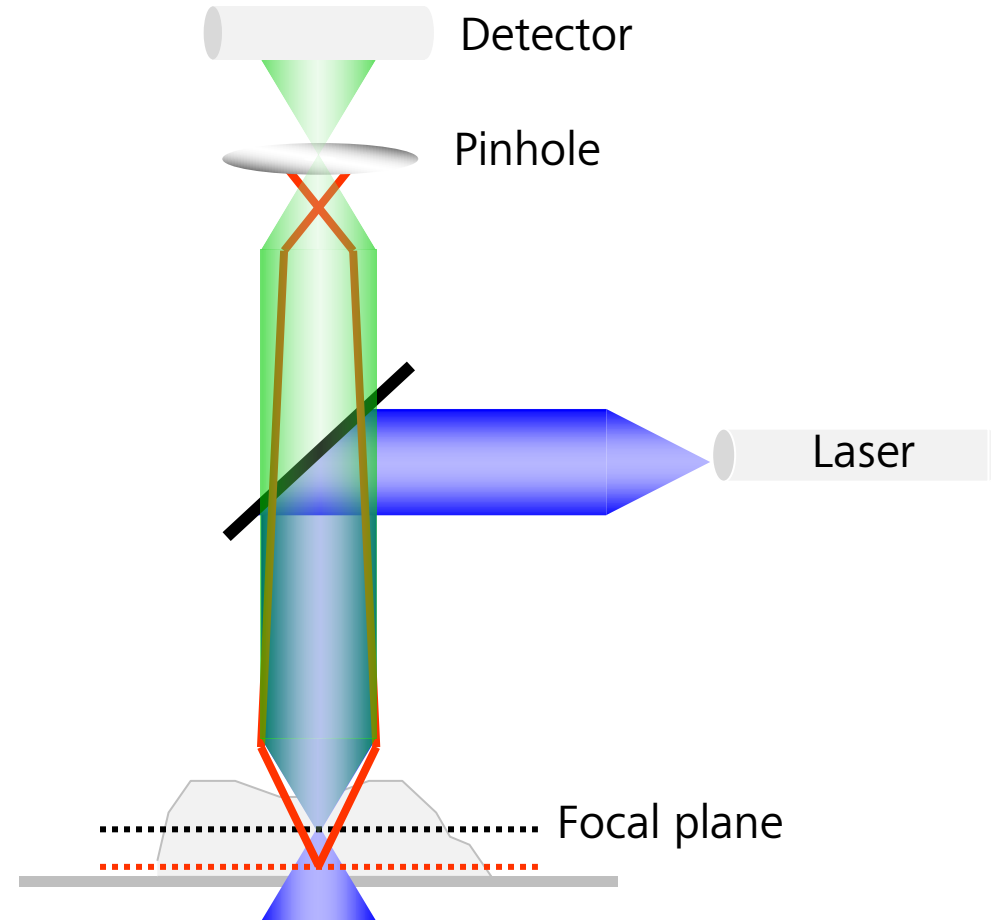

Point Scanning Confocal Microscopes

Confocal principle

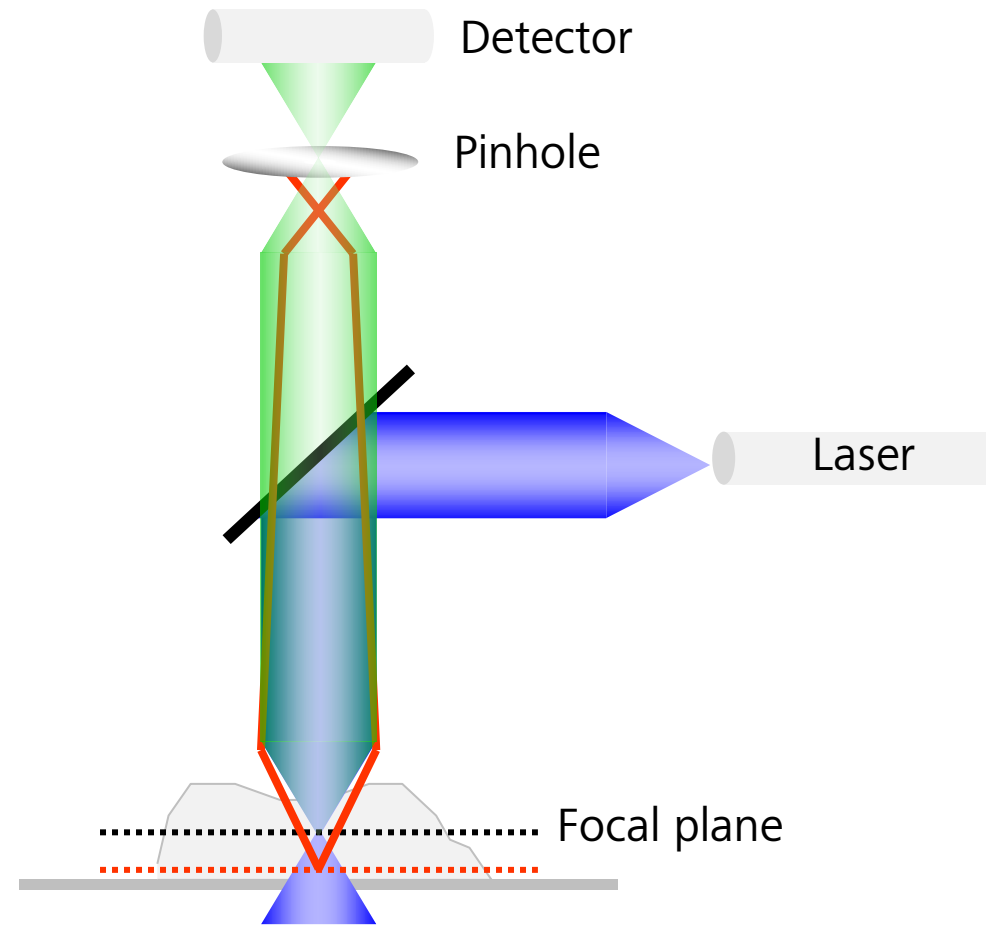
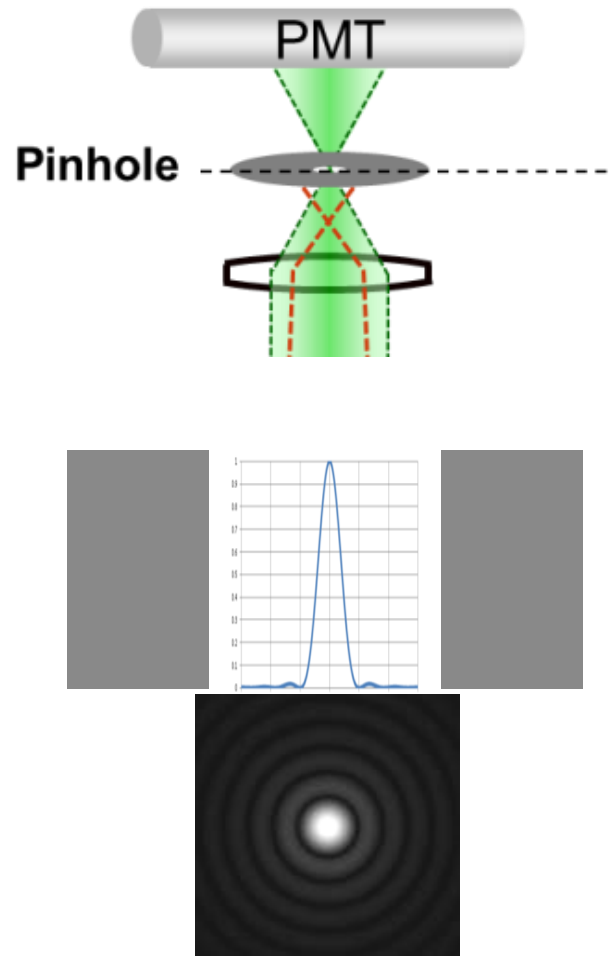

Point Scanning Confocal Microscopes

Confocal principle

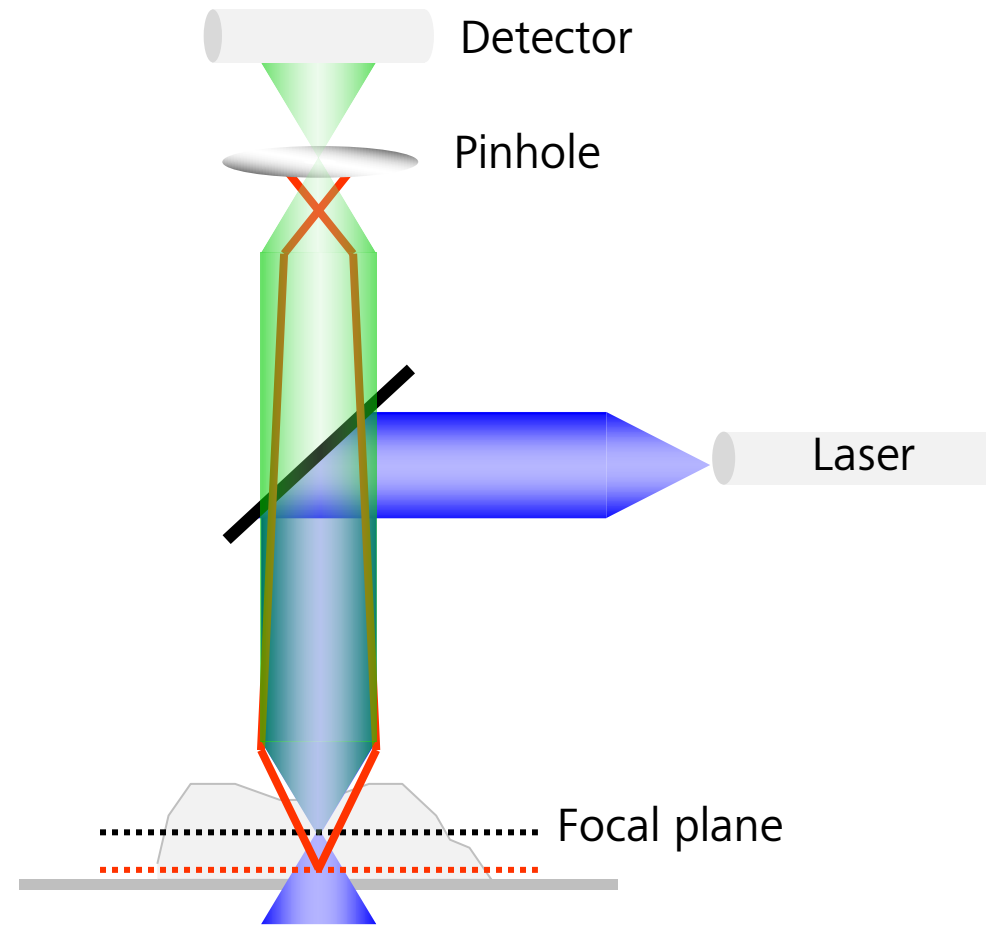
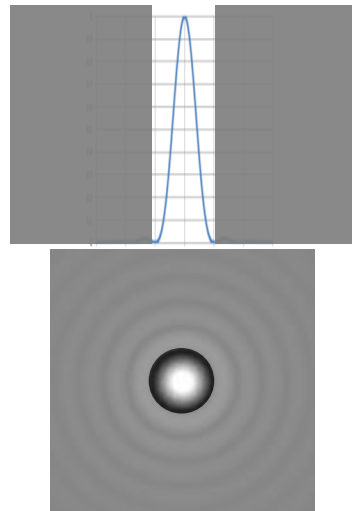
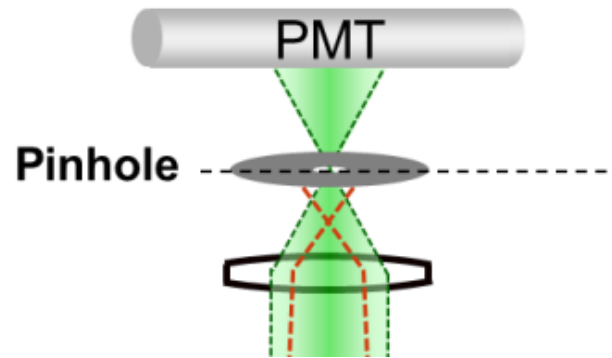

From a Single Spot to a Complete Image

Spot Illumination Requires Two-dimensional Scanning

X-Y scanning

To generate a two-dimensional image, the laser spot is scanned in x and y direction to illuminate the whole field of view.

This is usually done by scanning mirrors.

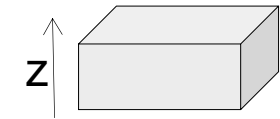
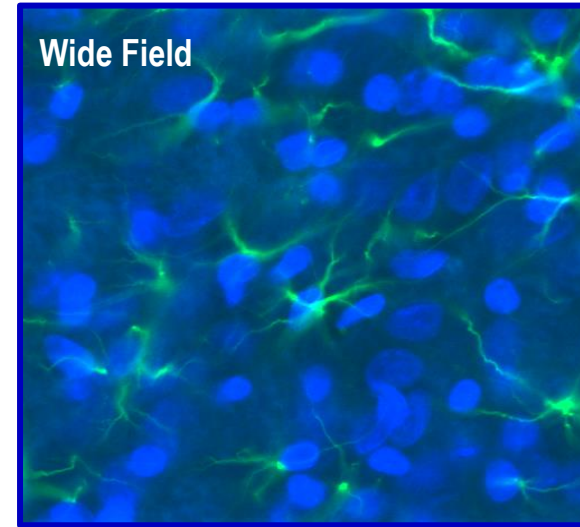
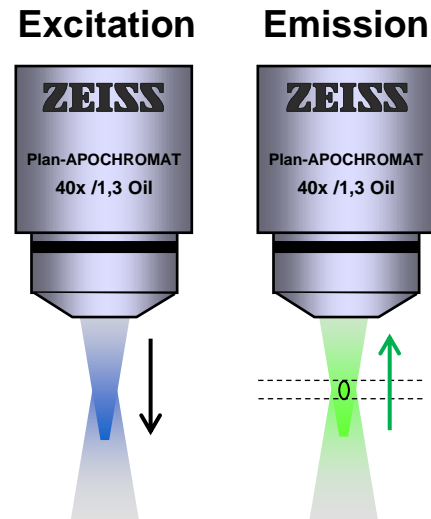
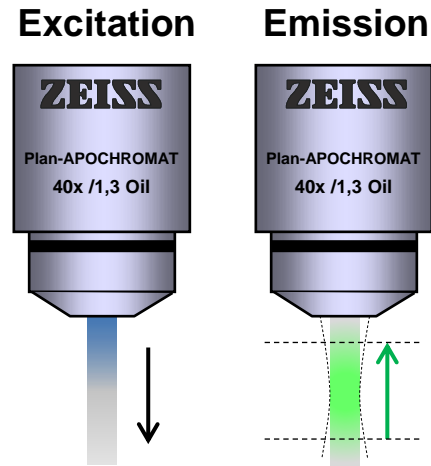

limited z-resolution
thick sections

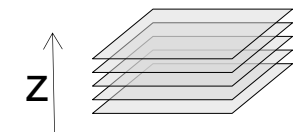

high z-resolution
3D via sectioning

The Leibniz Institute of Plant Genetics and Crop Plant Research (IPK), Germany Breeding Research on the Way to a Plant-Based Bioeconomy



Microscopy is an important link between the different research groups.

Michael Melzer | IPK Gatersleben



Your needs our motivation

Scaling from 2D Cell Cultures to New 3D Model Systems

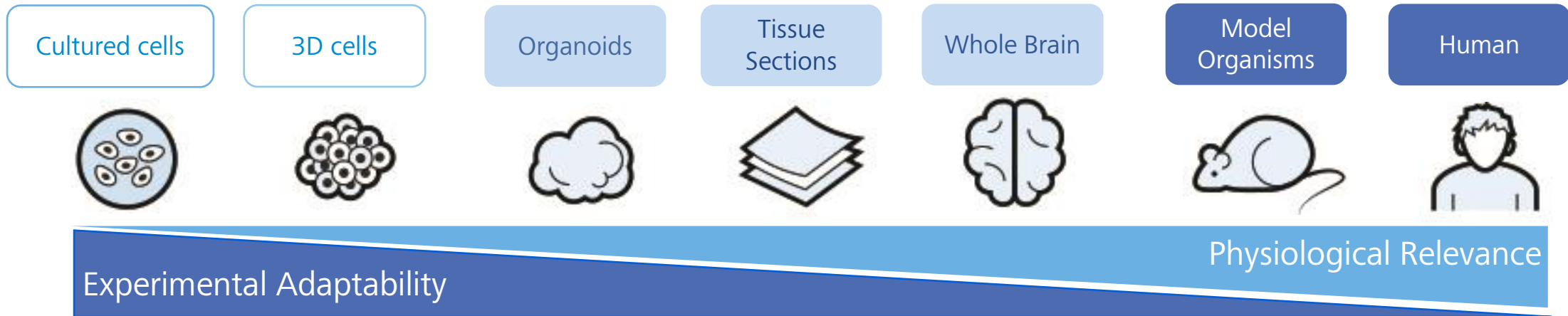

Adapted from <https://academic.oup.com/ib/article-abstract/8/6/672/5115178>

Your needs our motivation

Scaling from 2D Cell Cultures to New 3D Model Systems

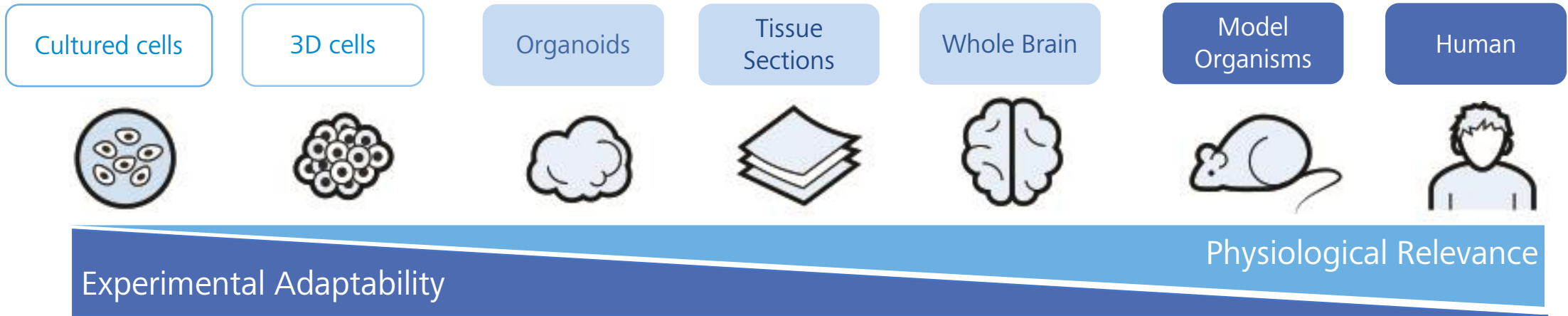

Adapted from <https://academic.oup.com/ib/article-abstract/8/6/672/5115178>

Molecular Dynamics

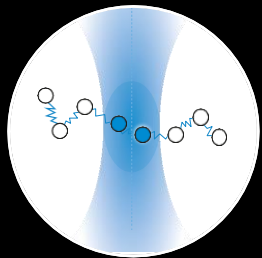

1 μm

Superresolution

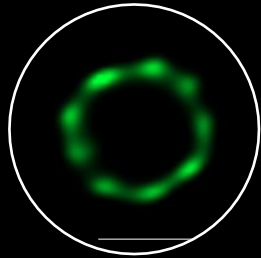

Structural Analysis

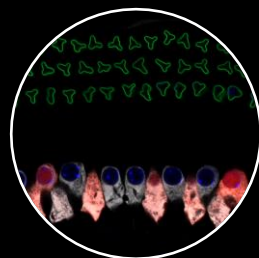

10 μm

Multicolour imaging

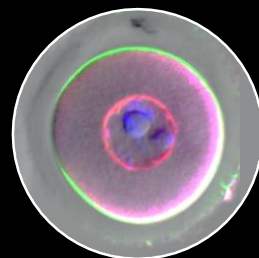

50 μm

Large volumes

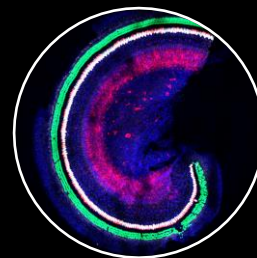

Depth imaging

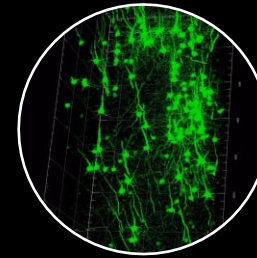

1 mm

High throughput

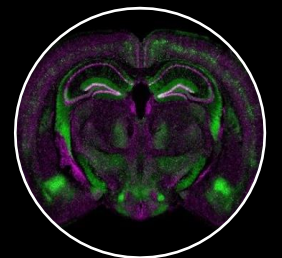

1 cm

Integrated Imaging Platform



Confocal imaging



Snap

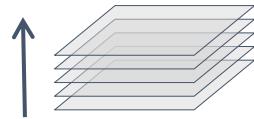

Z-Stack

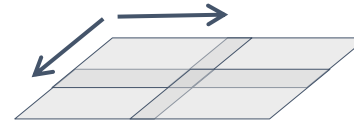

Tiles

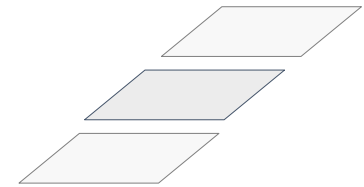

Time Series

Software

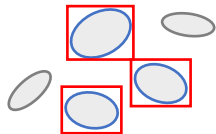
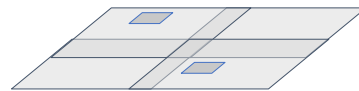
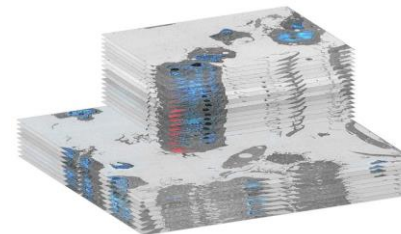

Image Analysis



ZEN connect



Correlative
Microscopy

High Resolution Optical Sectioning

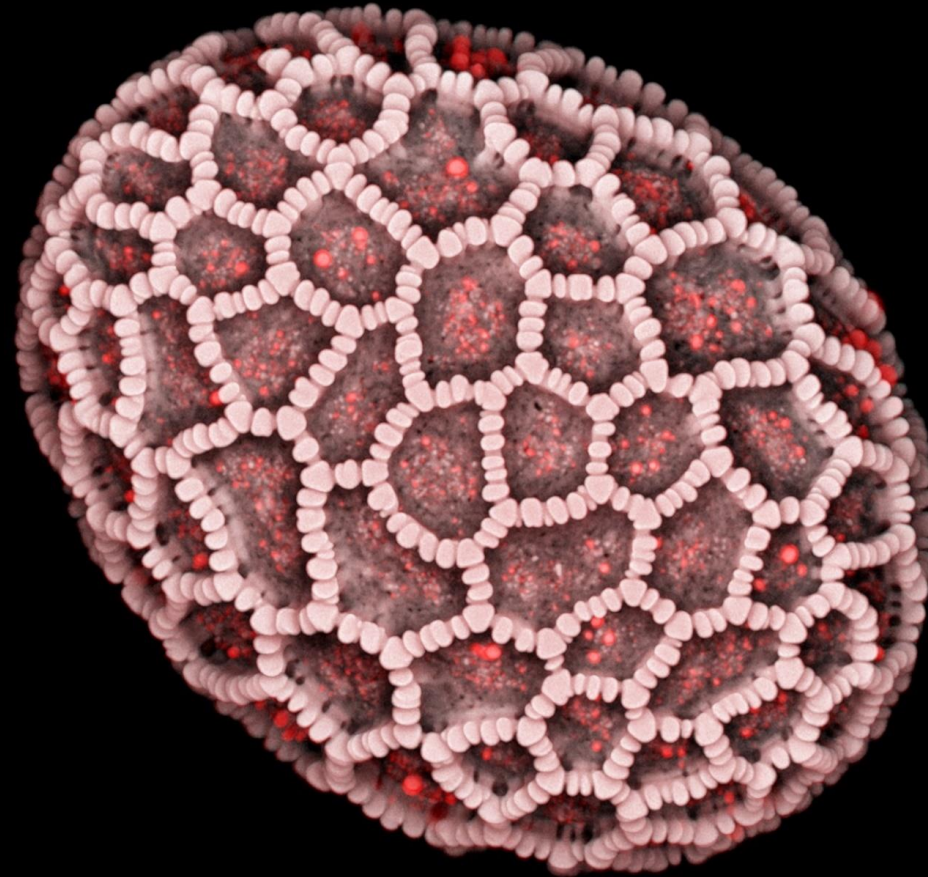
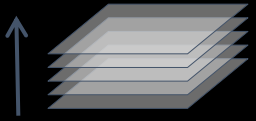

High Resolution Optical Sectioning

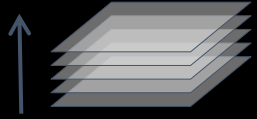

LSM

SEM

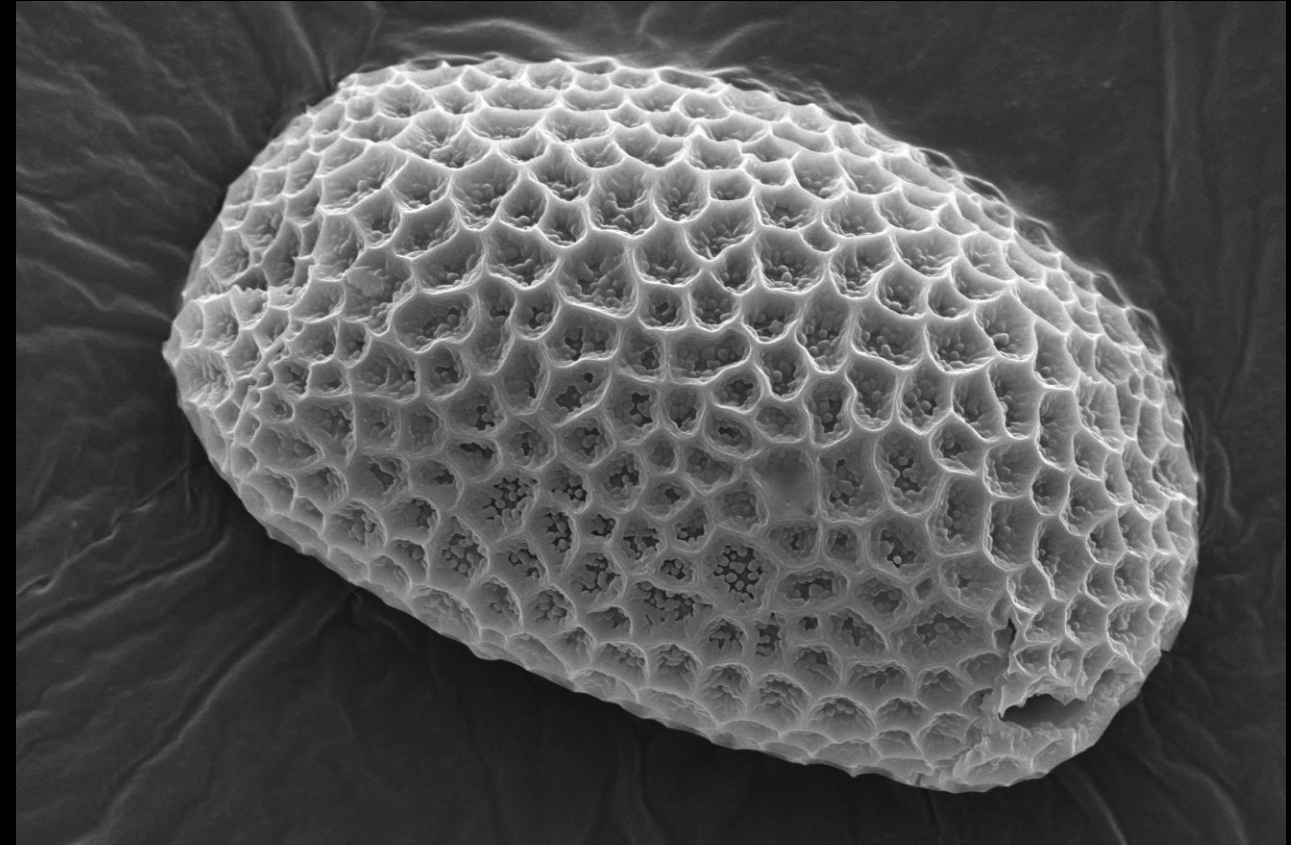
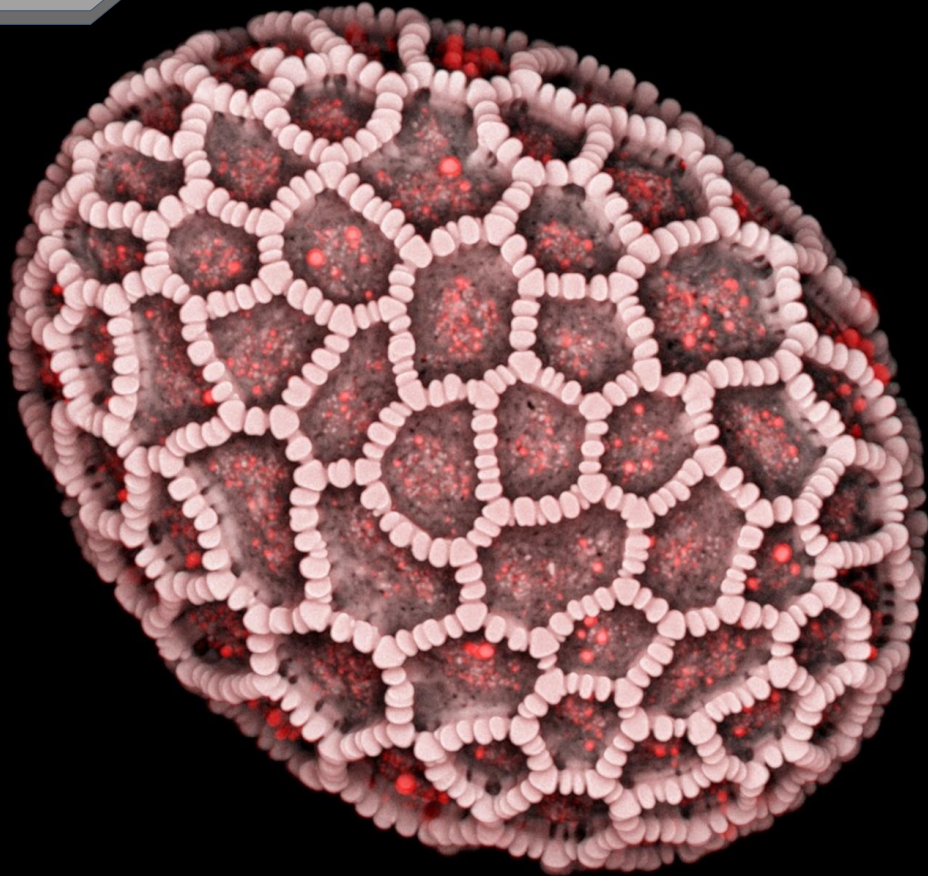

Sensitive & Speedy Imaging

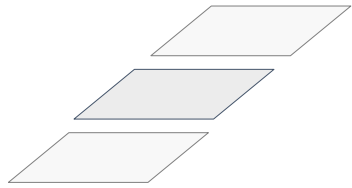

Time series

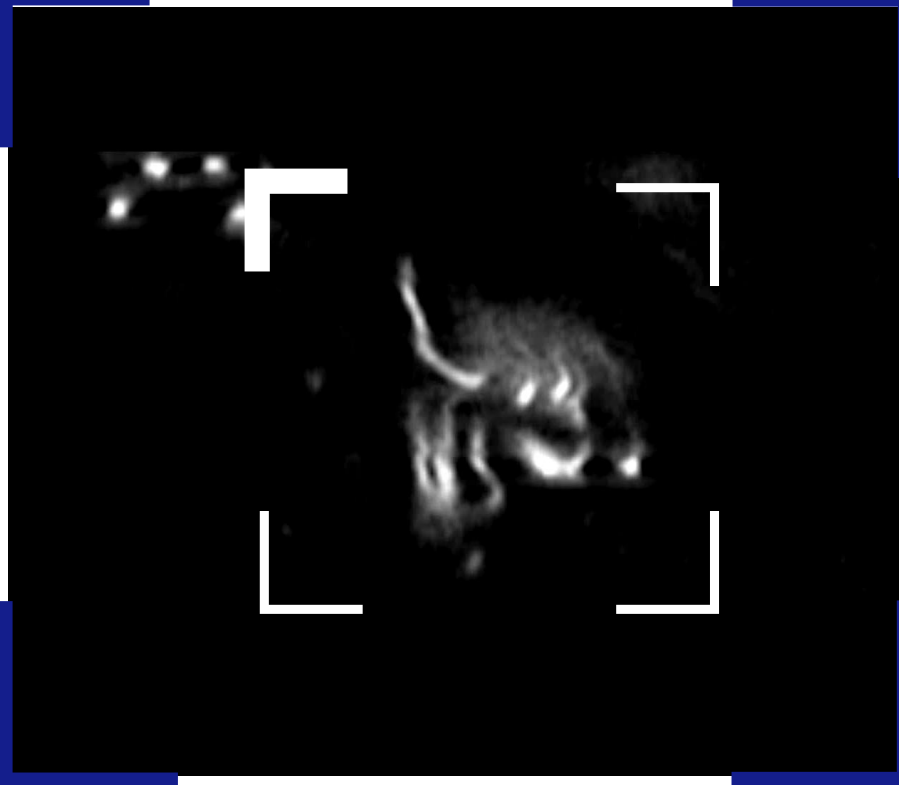

Data courtesy of Ann-Kathrin Günther & Dr. Gregor Eichele, MPI for Biophysical Chemistry, Göttingen, Germany

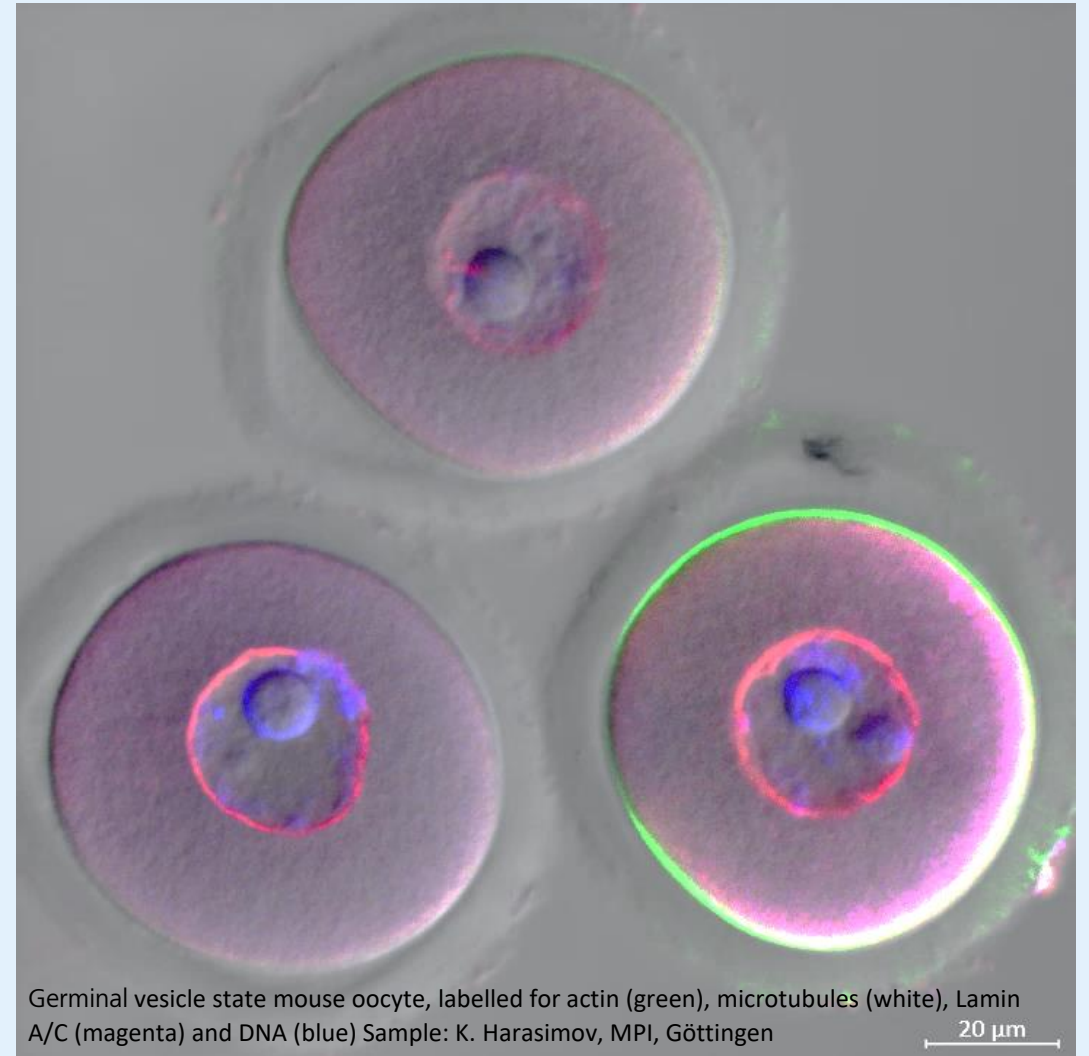

Germinal vesicle state mouse oocyte, labelled for actin (green), microtubules (white), Lamin A/C (magenta) and DNA (blue) Sample: K. Harasimov, MPI, Göttingen

20 μm

Acquire Large Volumes at Best Quality

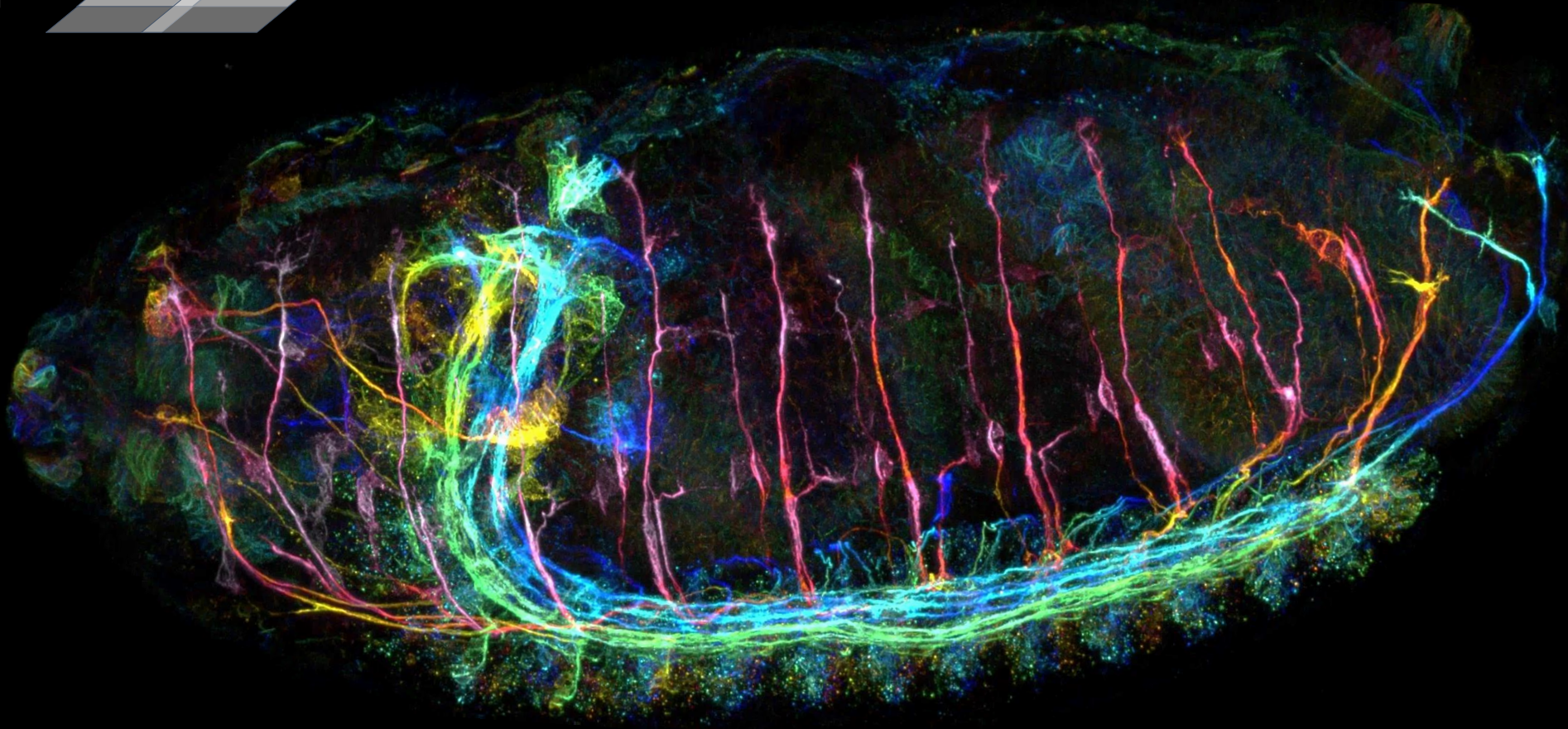
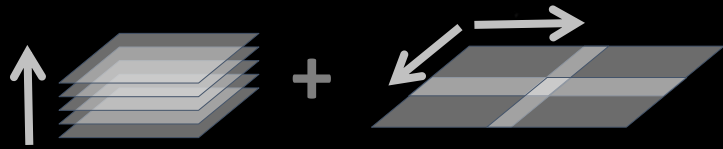

Drosophila melanogaster, CNS and PNS depth coded, Airyscan Multiplex mode. Courtesy of Julia Sellin, LIMES, Bonn, Germany

Large Volume Imaging

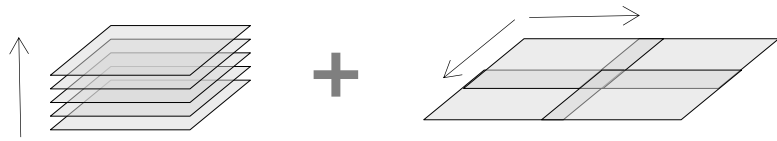

Adult mouse brain

Thy1-GFP (Neurons)

CLARITY

12 tiles and 800 μ m z-stack

Total sample depth 1.4mm

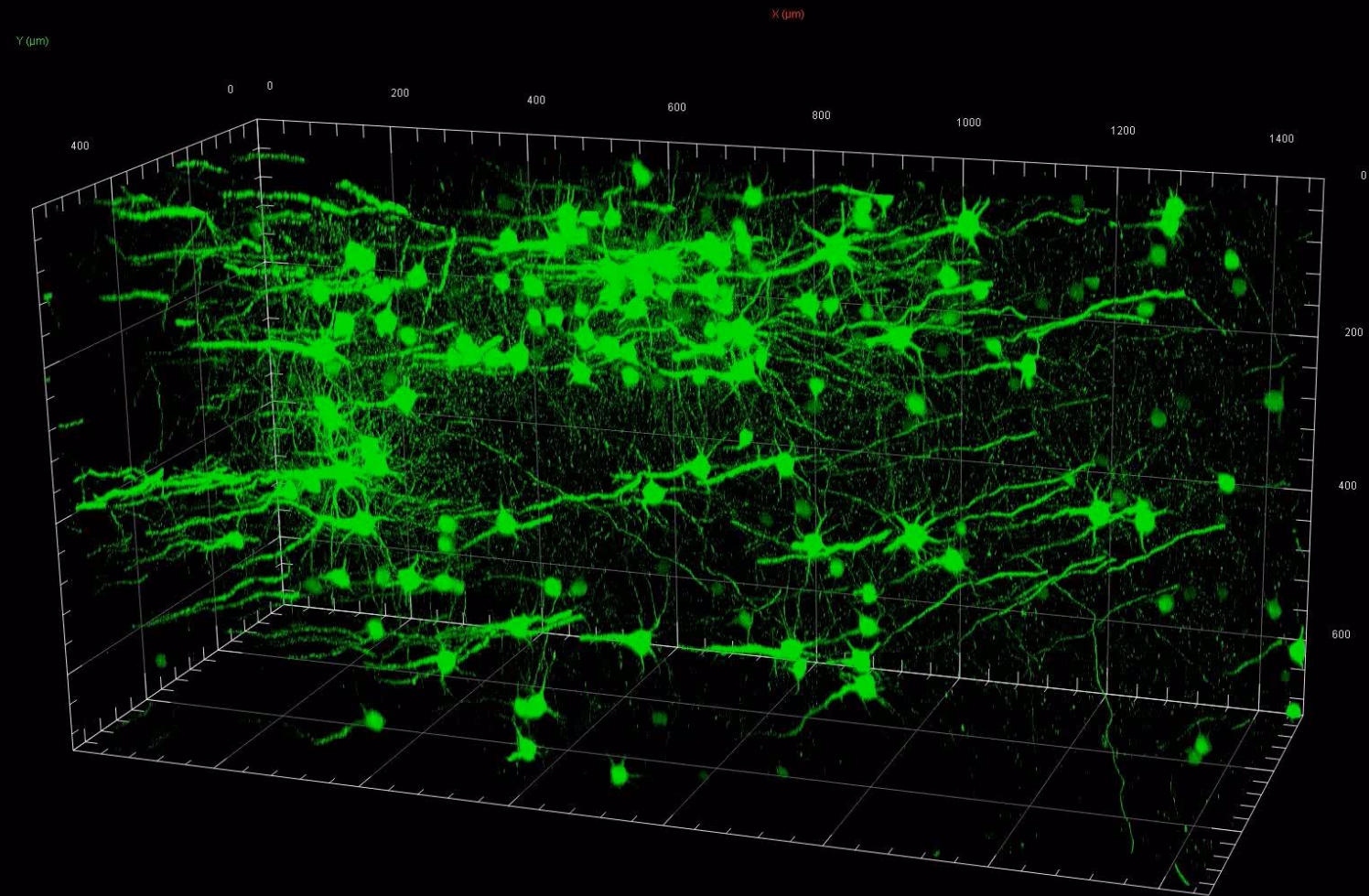

Tobias Ruff, Max Planck Institute of Neurobiology,
Martinsried (Munich), Germany.

Spatial Biology Studies in Lung Tissue using Spectral Microscopy



Spectral Unmixing

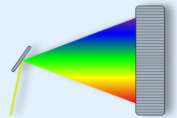

Identification of macrophage niches in wounded lungs

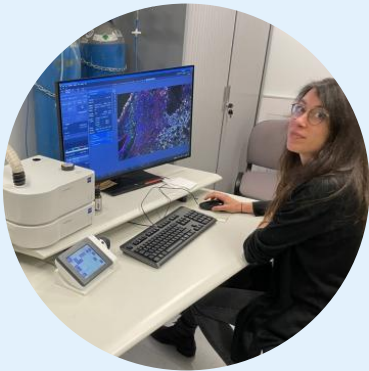
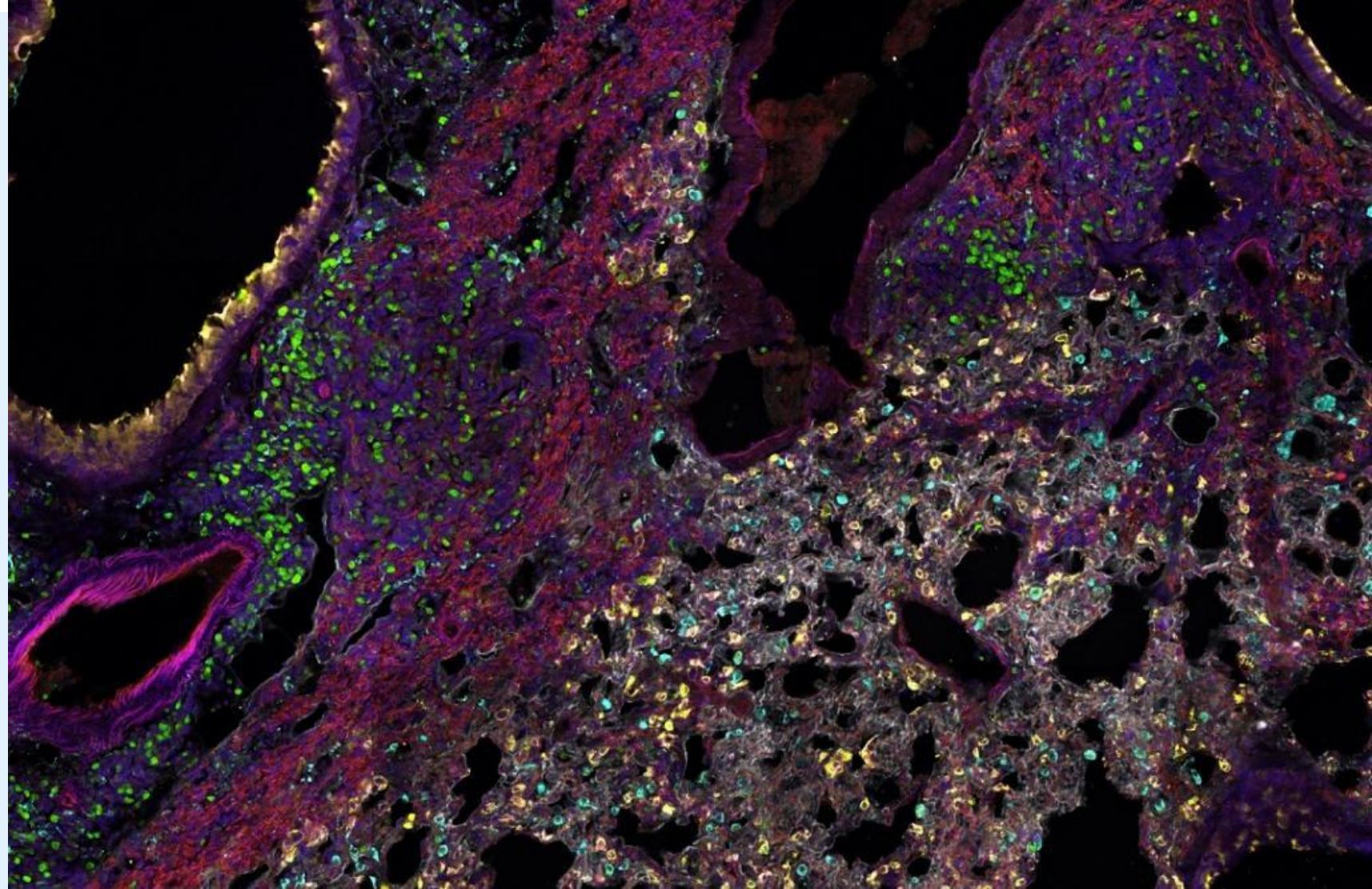

Cecilia Ruscitti

PhD Student at the Laboratory of Immunophysiology
Supervised by Dr. Thomas Marichal, University of Liège, Belgium

Keep the Context of Your Experiments

X-ray

Light Microscopy

Electron Microscopy

Ion

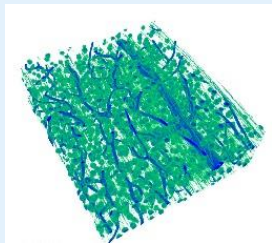

X-ray

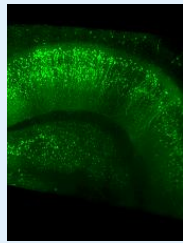

Lightsheet

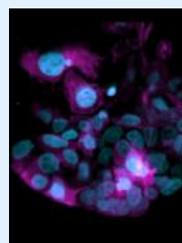

Lattice
Lightsheet

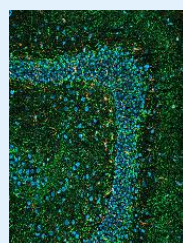

Widefield

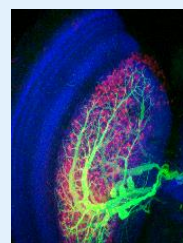

LSM
Airyscan

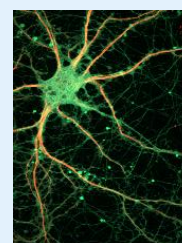

Super-
resolution

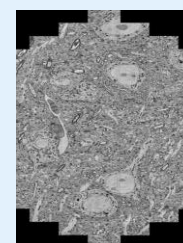

MultiSEM

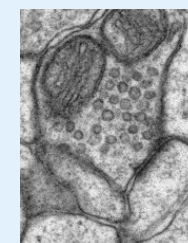

Field Emission
Scanning Electron

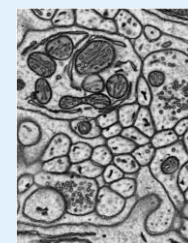

Focused
Ion Beam



Helium Ion

700 nm

500 nm

290 nm

250 nm

120 nm

20 nm

5 nm

< 2 nm

< 1 nm

< 0.5 nm



Why Correlative Microscopy ?

X-ray

Light Microscopy

Electron Microscopy

Ion



Dive into ultrastructure



Multi-dimensional research

700 nm

500 nm

290 nm

250 nm

120 nm

20 nm

5 nm

< 2 nm

< 1 nm

< 0.5 nm



Confocal Microscope to FIB/SEM for Targeted Milling

Correlative Microscopy

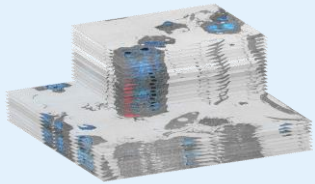

- Connect various microscopy system (i.e., LM, EM, XRM)
- Combine analytical solution (i.e., Raman, EDS)

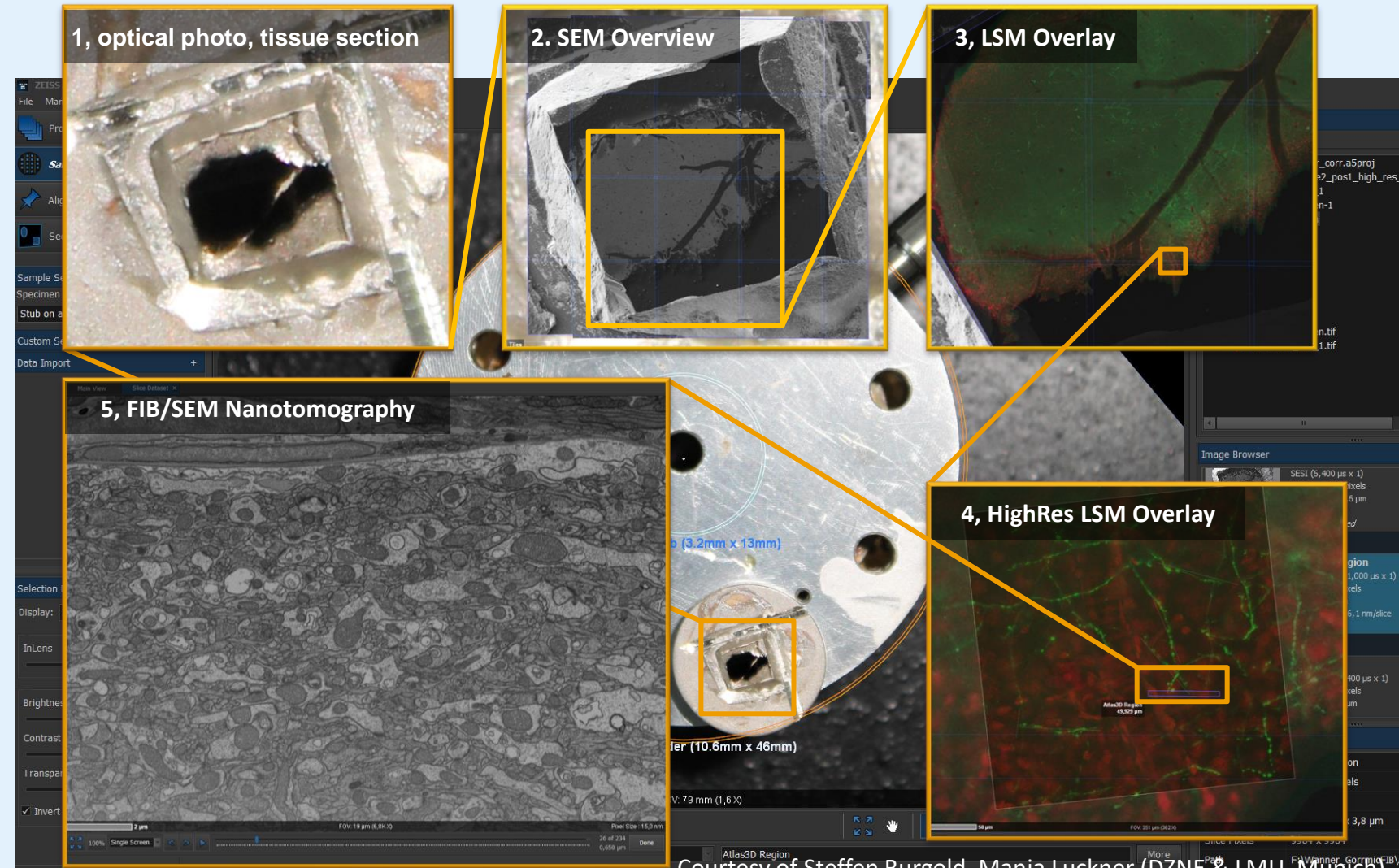

Effortless Image Acquisition and Analysis

Data Integration between Different Imaging Modalities



ZEN Connect

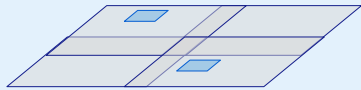

- Overlay and alignment of all your images
- Intelligent data management

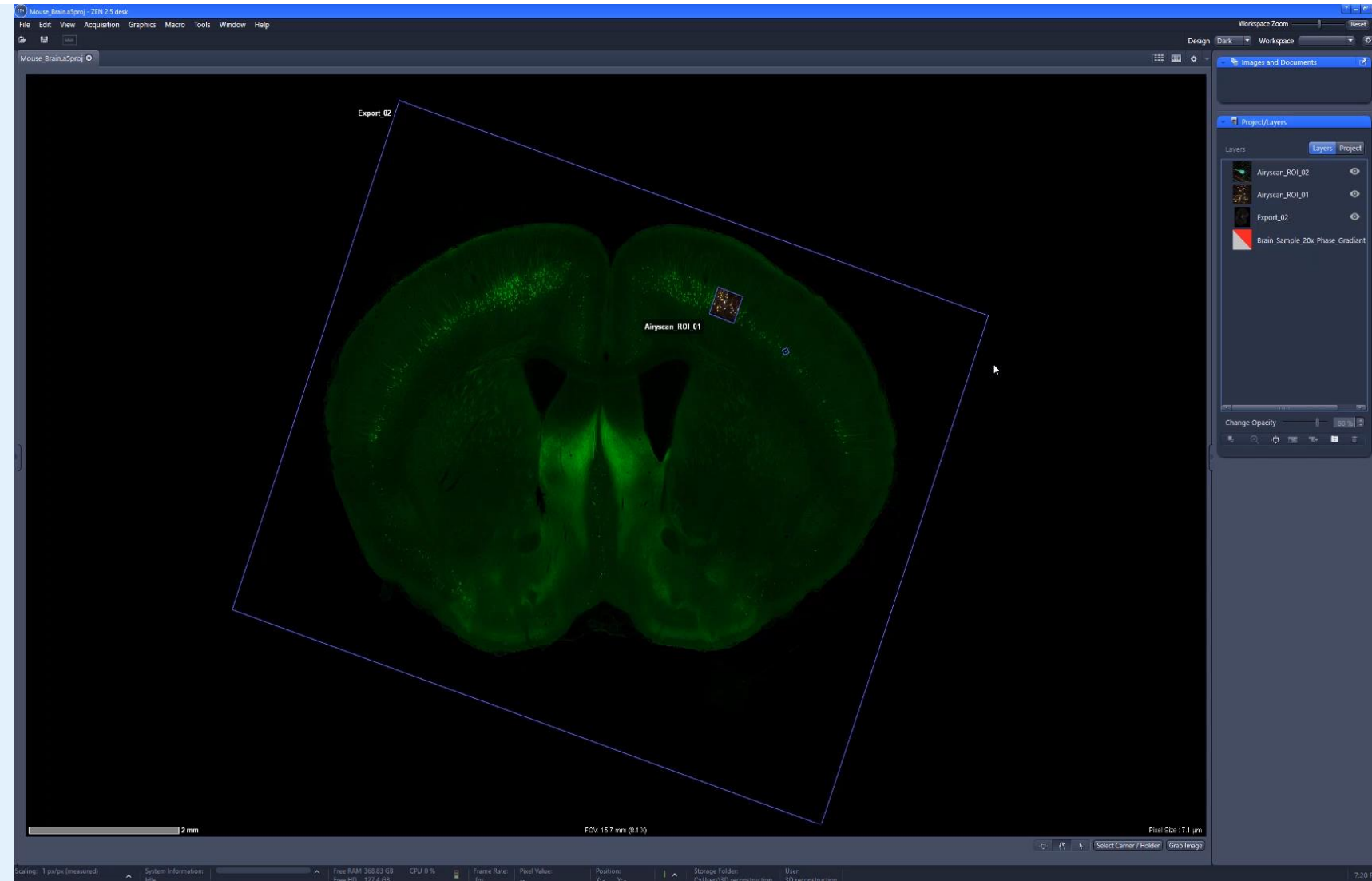

Convenient Overview & Navigation

Navigated Imaging

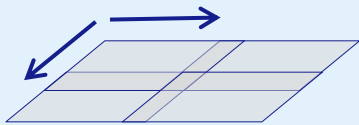

Acquire general view of zebra fish at low magnification

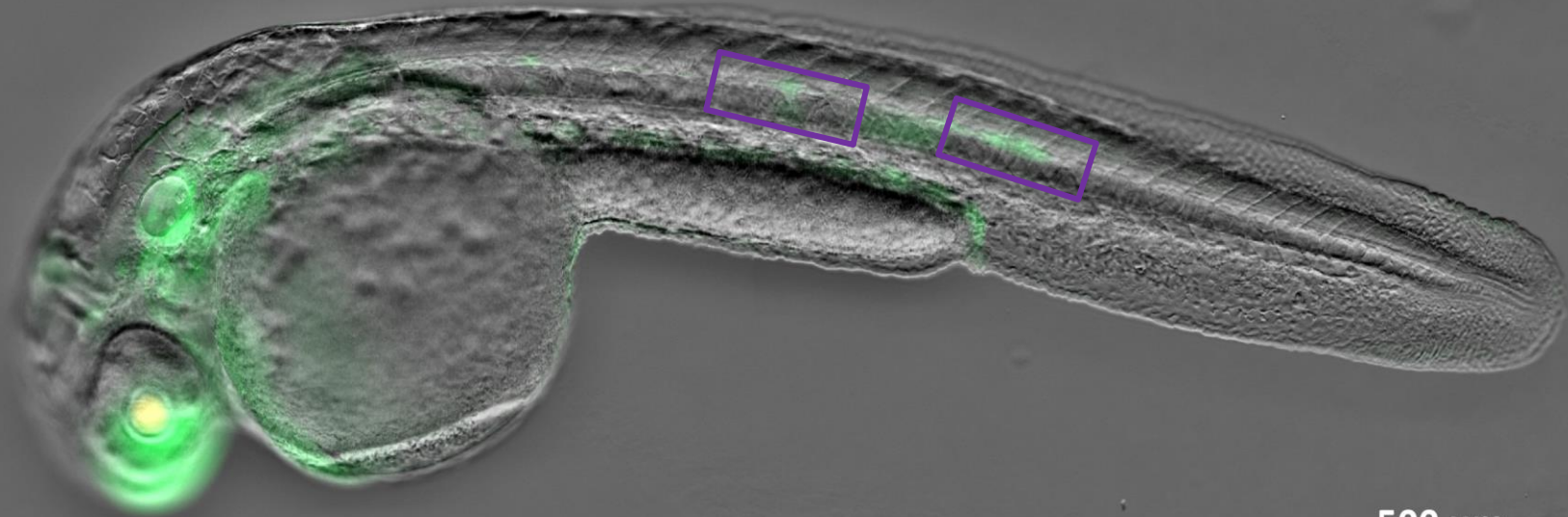

Convenient Overview & Navigation

Navigated Imaging

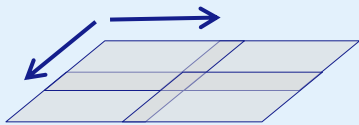
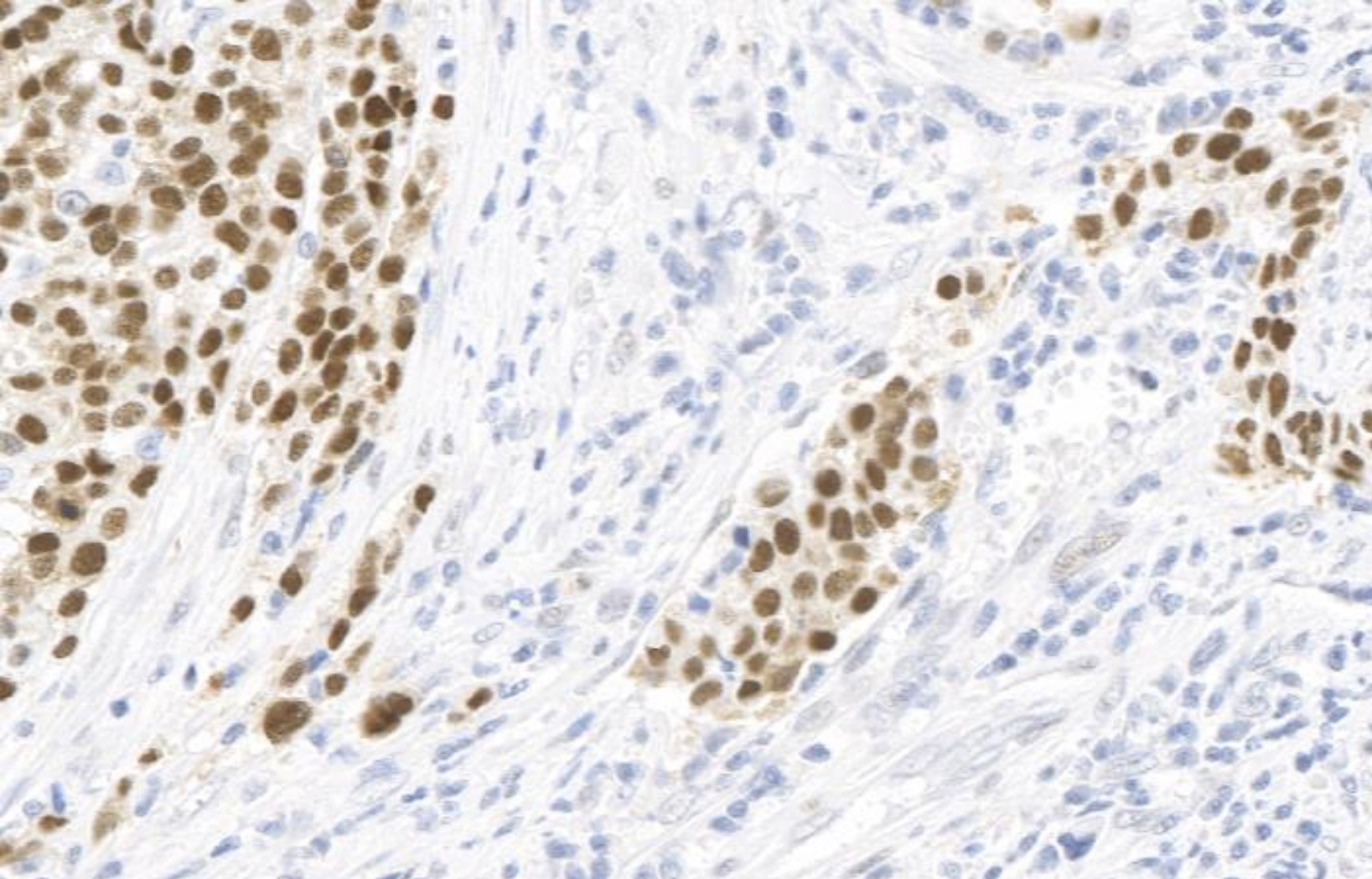

Image neuromast and lateral line with high resolution



Microscopy Images: A Picture is worth a thousand words!



How Many Cells are DAB positive?

- A: 1-10%
- B: 10-20%
- C: 20-30%
- D: 30-40%

Microscopy Images: A Picture is worth a thousand words!

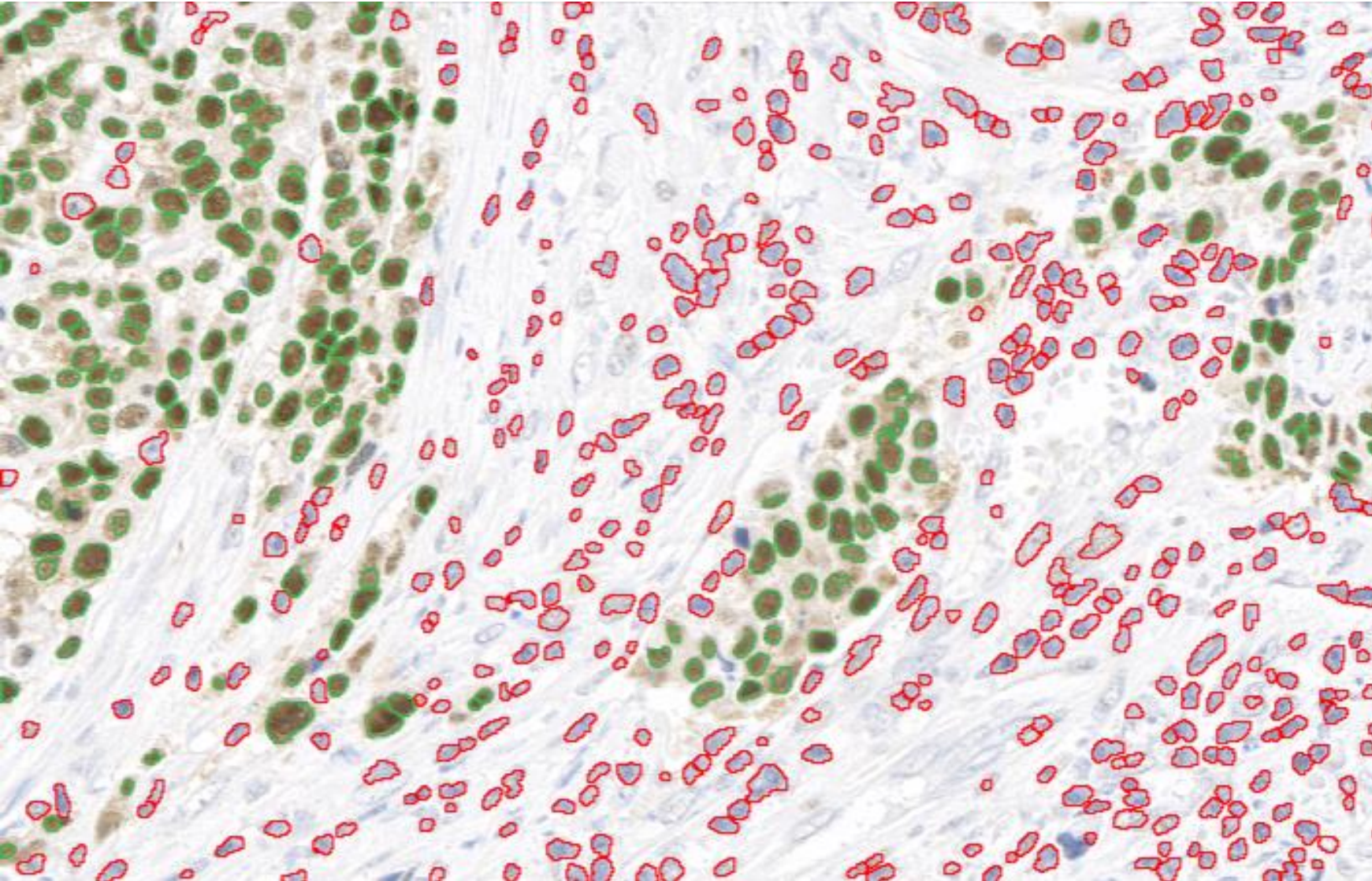

How Many Cells are DAB positive?

- A: 1-10%
- B: 10-20%
- C: 20-30%
- D: 30-40%

$$DAB = \frac{234}{234 + 418} \% = 35.9\%$$

ZEISS Image Analysis Software



Image Analysis

Flexible analysis pipeline

BioApps

AI-powered image analysis
for specific application



arivis

arivis Pro

3D image analysis and
visualization

Local AI image analysis

arivis Cloud

Cloud-based AI image
analysis

Image Analysis Workflow

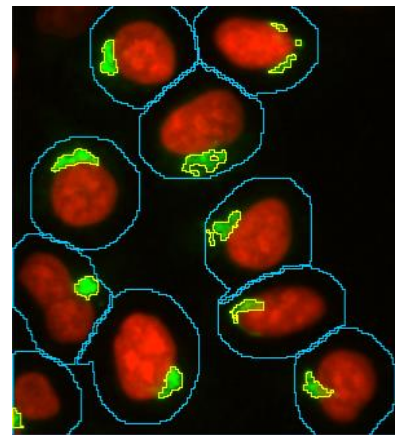
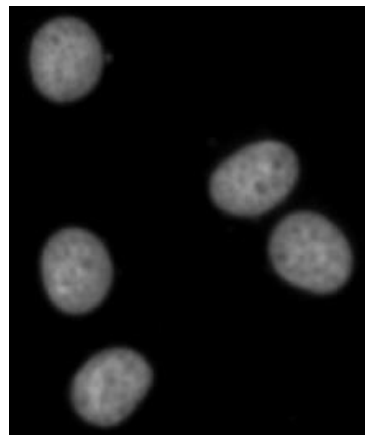
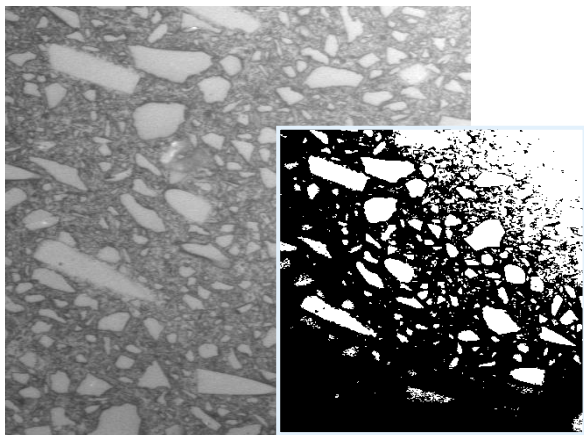

Object association



Heatmap for HCS

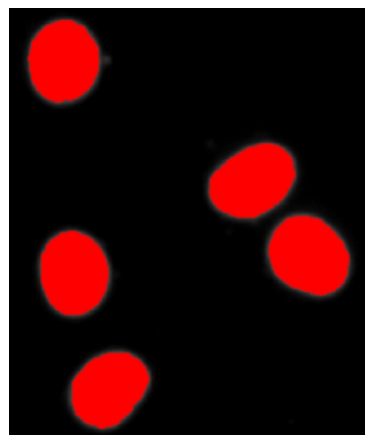
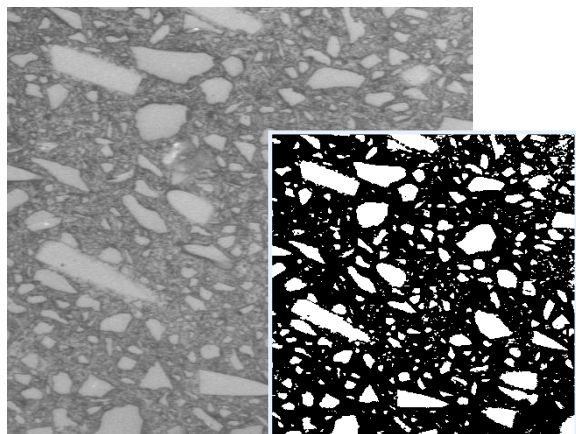

Scatter plot for relationship analysis

ID	Intensity...	Area [µm ²]	Roundness	
1	2	3,828.036	156.287	0.710
2	3	3,557.861	169.015	0.569
3	4	4,241.335	146.652	0.802
4	5	3,663.464	160.925	0.762
5	6	3,336.314	155.927	0.718
6	7	4,302.819	153.608	0.736
7	8	3,443.283	173.962	0.697
8	9	3,737.238	166.439	0.826
9	10	4,315.105	158.297	0.688

Feature measurements



Scatter plot for relationship analysis

Intuitive Analysis Workflow

ZEN Image Analysis

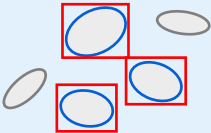

- Step-by-step analysis workflow
- Customize analysis
- Acquire statistical results

Display Analysis Results For:

Table Overview: Well

Name	Area [μm ²]	Area...
B	C	D
B2	712399.56	27.08
B3	1435554.79	54.57
B4	513280.12	19.51
B5	149579.07	5.69
B6	190512.48	7.24
B7	390915.87	14.88
B8	279297.97	10.62
B9	507667.80	19.30
B10	1317867.35	50.09
B11	1171050.36	44.51
C2	179164.71	6.81
C3	330436.75	12.56
C4	265942.72	10.11
C5	126115.97	4.79
C6	458343.06	17.42
C7	831327.19	31.60
C8	619155.72	23.53
C9	417527.19	15.87
C10	1112908.66	42.34
C11	1064858.61	40.48
D2	294096.85	11.18
D3	608697.91	23.14
D4	113768.23	4.32
D5	240715.28	9.15
PK	1002172.08	14.17

Display: Heatmap

	1	2	3	4	5	6
A	○	○	○	○	○	○
B	○	●	●	●	●	●
C	○	●	●	●	●	●
D	○	●	●	●	●	●
E	○	●	●	●	●	●
F	○	●	●	●	●	●
G	○	●	●	●	●	●
H	○	○	○	○	○	○

Area Percentage [%]

11.945 μm

2D Segmentation

ZEN Image Analysis Wizard - ZEN MAIN (ZEN image processing)

Image Analysis Wizard

3/7 Automatic Segmentation

Execute Interactive

- Base 0
 - AllNuclei 1
 - SingleNucleus DAPI 2
 - AllSpots 3
 - SingleSpots EGFP 4

Apply
Intellesis Trainable Class Segmenter Select
Model Name SP100 Select Model
Model Class Object Reset
Min. Confidence (%) 51
Minimum Area 1
Min. Hole Area 1
Fill Holes
Binary None
Separate None

Next

Dimensions Display

Zoom 100% 37%
Tools
Channels DAPI EGFP
 Single Channel Range Indicator

Show All

Analysis

Show Objects Fill Opacity
 Show All Classes

- Base 0
 - AllNuclei 1
 - SingleNucleus DAPI 2
 - AllSpots 3
 - SingleSpots EGFP 4

< Back Next > Finish Cancel

3D Segmentation using a RF-based model in ZEN blue

The screenshot displays the ZEN blue software interface for 3D segmentation. The central 3D view shows a grayscale volume with several red segmented regions. Each region is enclosed in a magenta bounding box. The axes are labeled X (μm), Y (μm), and Z (μm). The X-axis ranges from 0 to 320, the Y-axis from 0 to 240, and the Z-axis from 0 to 80. The left sidebar contains various tool icons such as 2D, Gallery, Ortho, 2.5D, 3D, Tomo3D, Profile, Histo, Measure, Analysis, Info, and Tree. The right sidebar features the 'Analysis Objects Table' and a 'Summary Table'.

Analysis Objects Table

Classes: Phase1 Export table

<input checked="" type="checkbox"/>	ID	Volume3	ParentID
<input checked="" type="checkbox"/>	2	2695.00	1
<input checked="" type="checkbox"/>	3	856.00	1
<input checked="" type="checkbox"/>	4	655.00	1
<input checked="" type="checkbox"/>	5	3535.00	1
<input checked="" type="checkbox"/>	6	3796.00	1
<input checked="" type="checkbox"/>	7	2086.00	1
<input checked="" type="checkbox"/>	8	823.00	1
<input checked="" type="checkbox"/>	9	1360.00	1
<input checked="" type="checkbox"/>	10	1591.00	1
<input checked="" type="checkbox"/>	11	856.00	1
<input checked="" type="checkbox"/>	12	2244.00	1
<input checked="" type="checkbox"/>	13	7604.00	1
<input checked="" type="checkbox"/>	14	43300.00	1
<input checked="" type="checkbox"/>	15	3203.00	1

Summary Table

RegionsCount	ID	ParentID
14	1	0

powered by arivis

Simple, Modular, AI-powered Image Analysis

BioApps

- Application-specific tools for cell-based imaging laboratories
- Easy-to-use with an intuitive user interface
- Concise results in easy-to-read formats

Intellesis

- Automated image segmentation powered by machine learning
- Use your expertise to train the software on your own images
- Analyze multimodal images from different sources

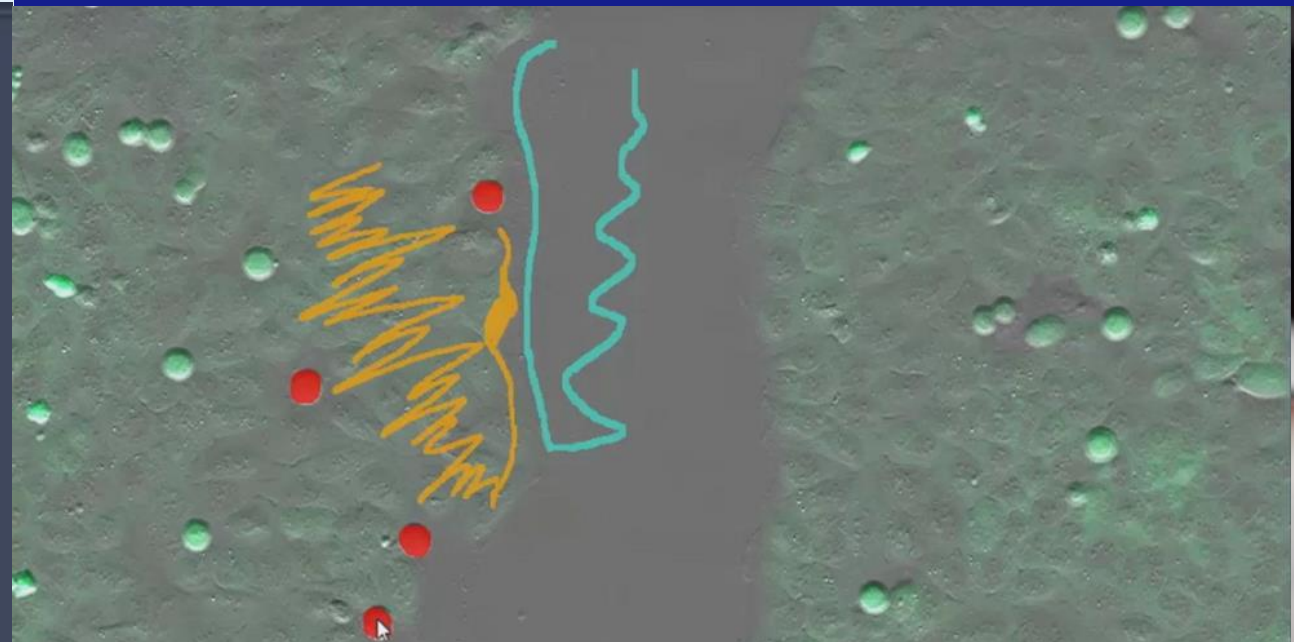
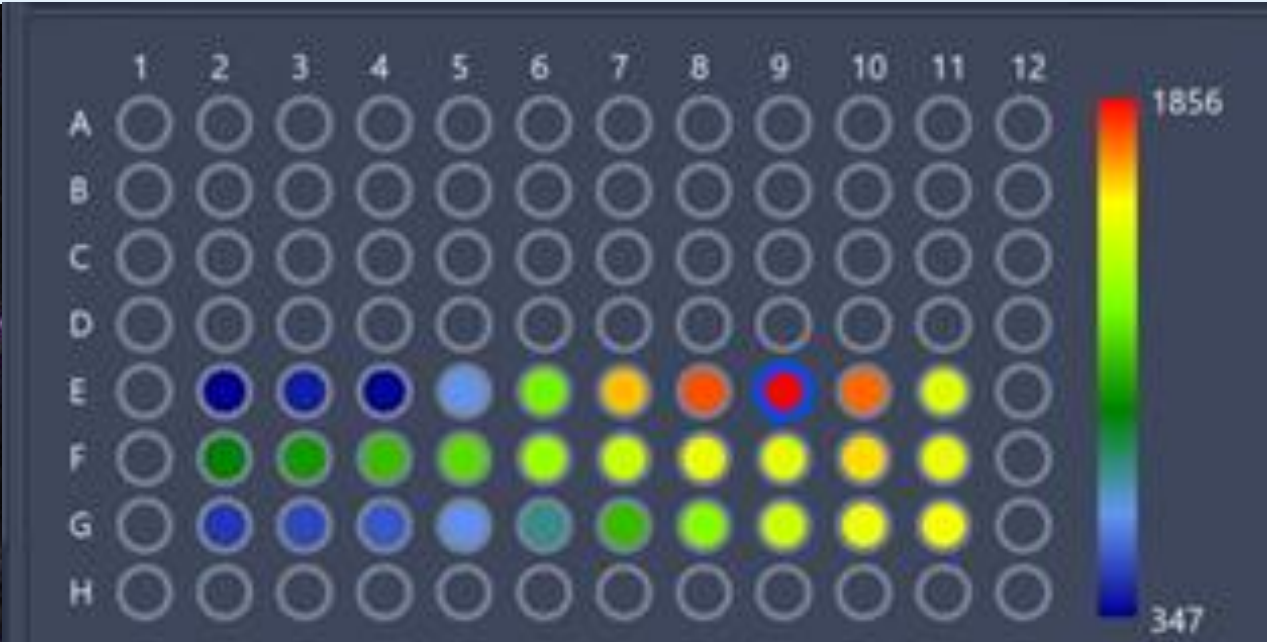

Intellesis – Simple User Interface

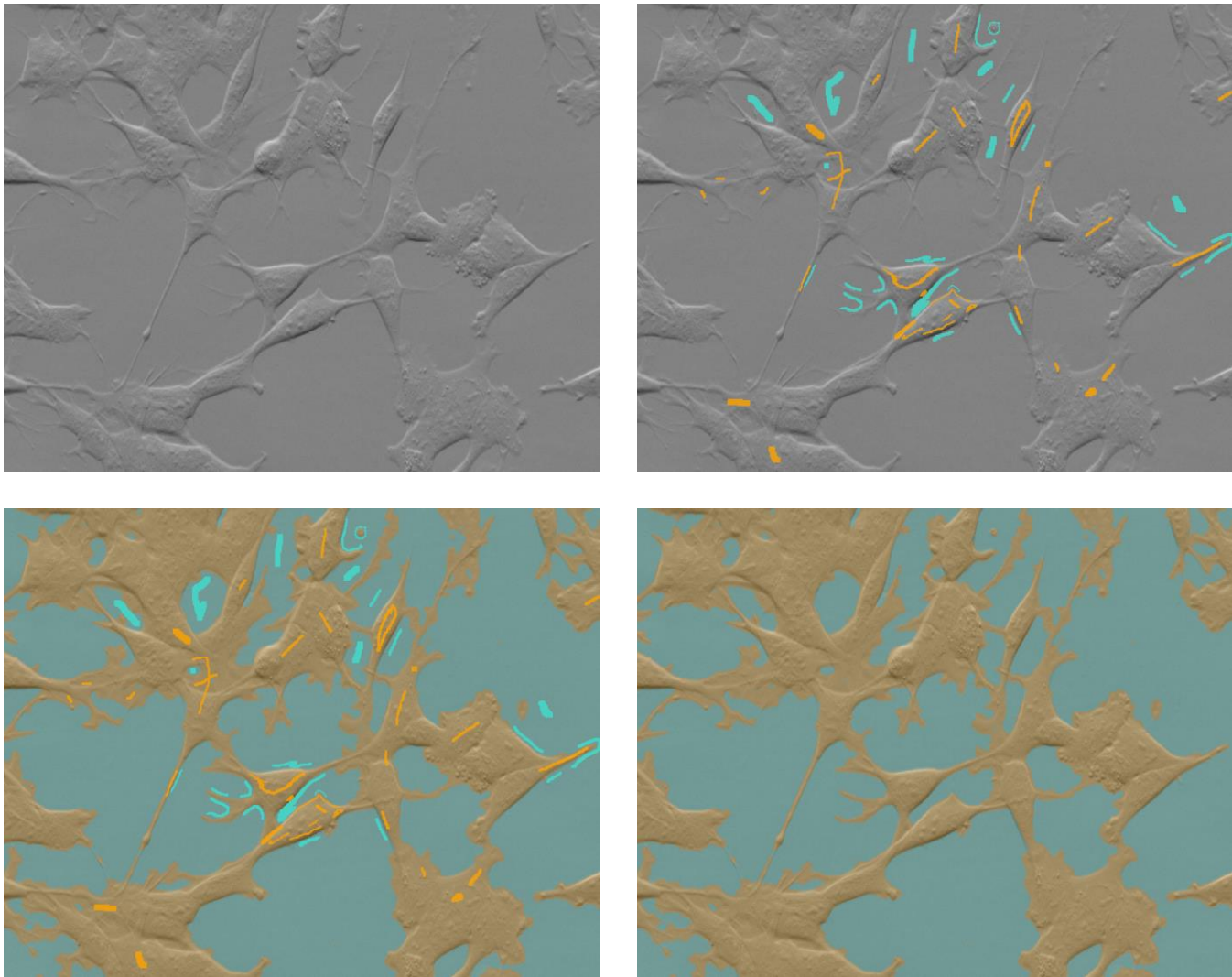

- Cells image using Phase-Gradient Contrast on a CD7
- Labeled with 2 classes inside Intellesis Training UI
- Feature Extractor: DeepFeatures256 + CRF Postprocessing

Out of the Box Solutions For All Research Topics in arivis Pro

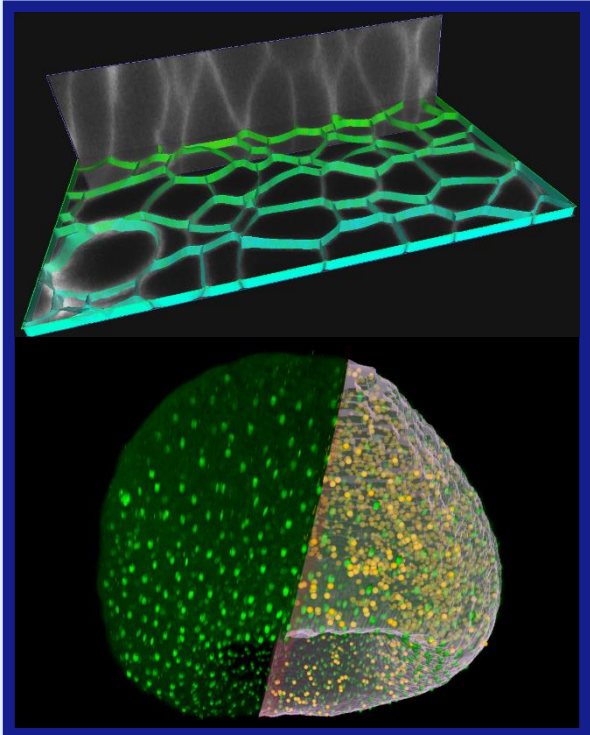

Developmental Biology

- Cell and Organelle Tracking
- 3D and 4D Analysis
- Membrane Segmentation

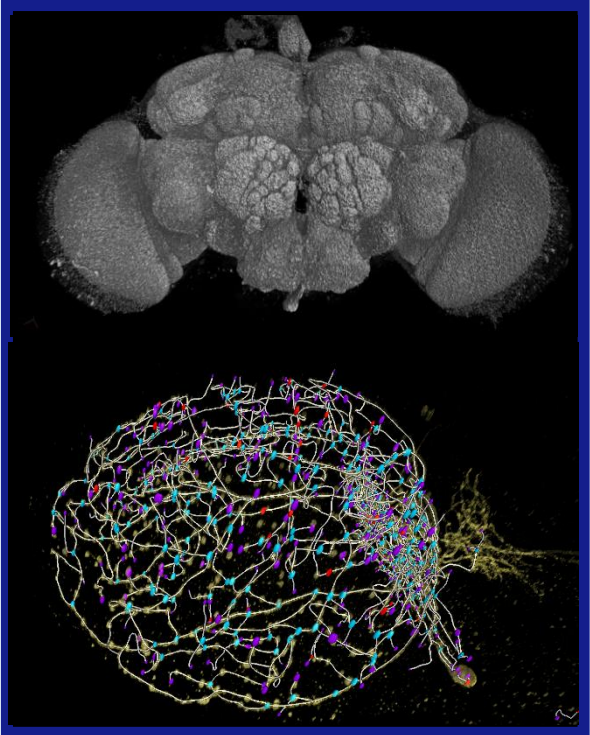

Neuroscience

- Compartment Analysis
- Distribution Analysis
- Stitching / Multi-view image reconstruction

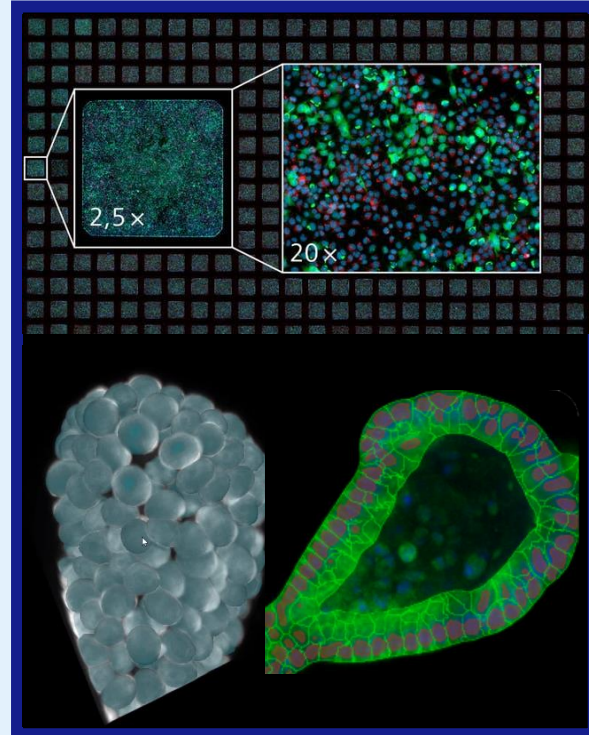

High Content

- Well-by-well analysis
- Cell counting
- Organoids and Spheroids

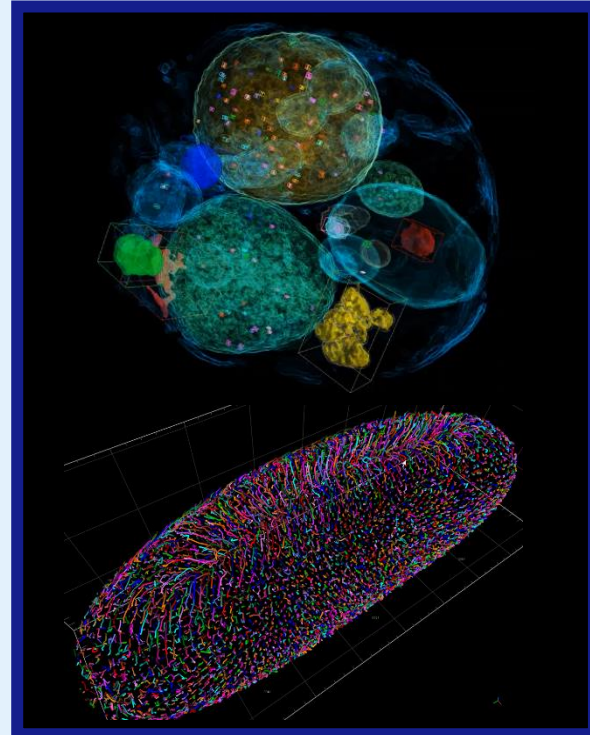

Cell Biology

- Organelle Analysis
- Distance Measurements
- Compartment Analysis

Gain Spatial Information using 3D Reconstruction

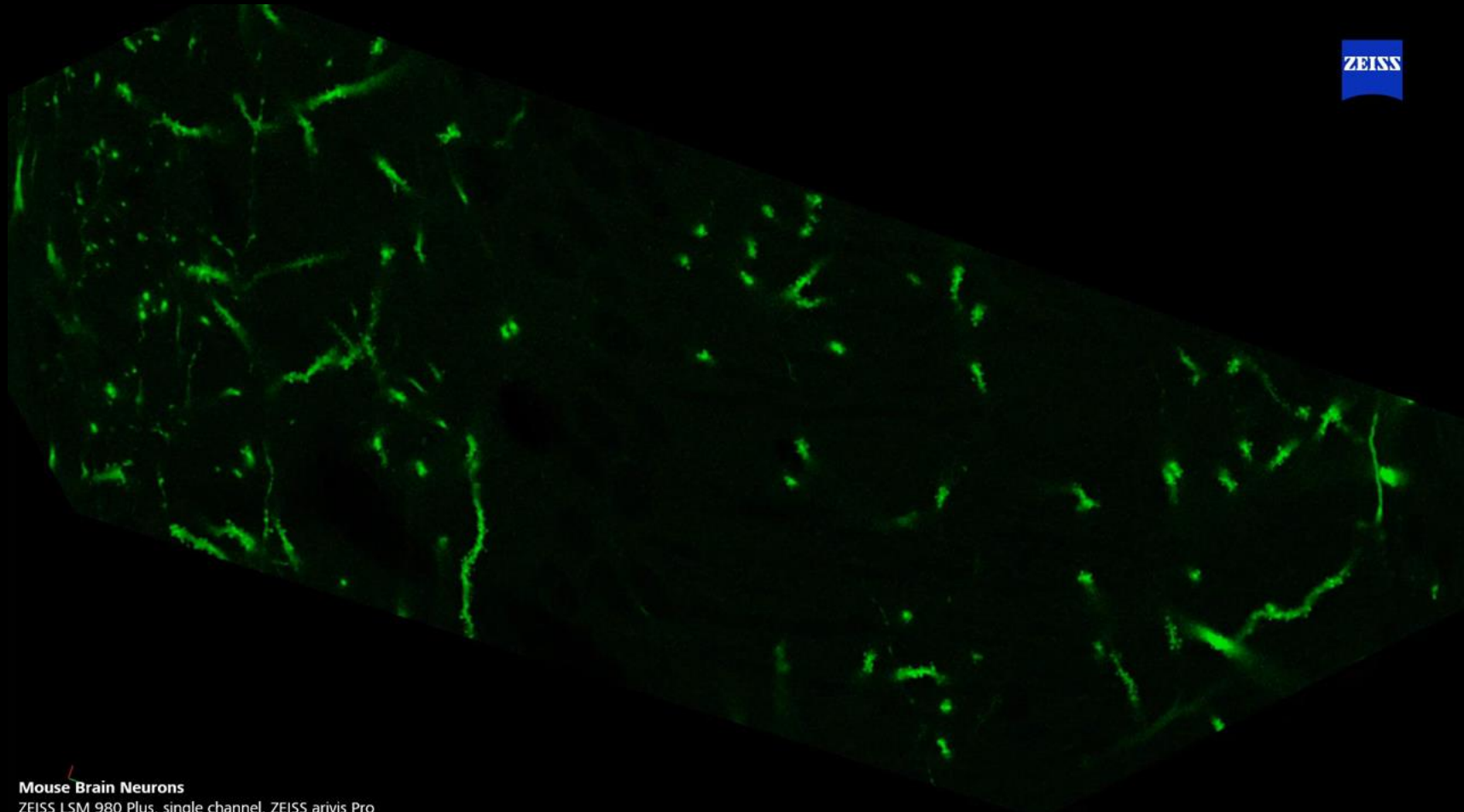

Mouse Brain Neurons
ZEISS LSM 980 Plus, single channel, ZEISS arivis Pro



Seeing beyond